

PrimeLine series for zones 1, 2 / 21, 22

Ex lighting fittings for demanding working conditions

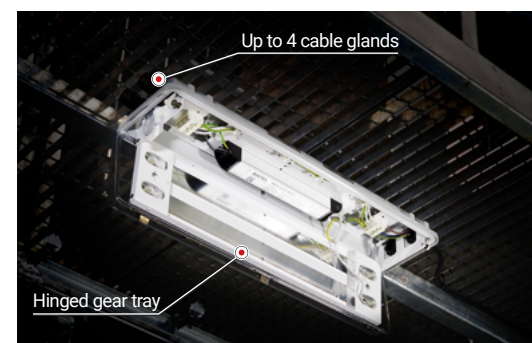
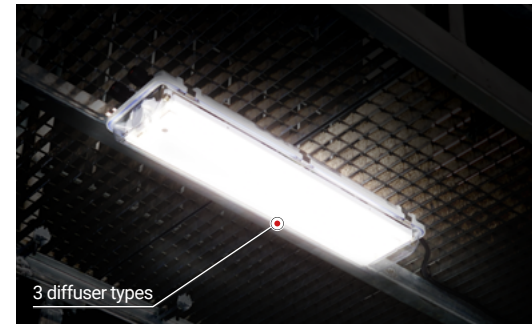

Application

Dust-proof, UV-resistant, and highly water-resistant linear luminaire, certified for Ex gas Zones 1 & 2 and dust Zones 21 & 22. Designed for demanding conditions, both indoor and outdoor. It replaces 18W/36W/58W fluorescent fixtures and reduces energy consumption. Designed for general and emergency lighting in production and warehouse facilities, it meets the specific requirements of industries such as:

- ▶ Oil and gas
- ▶ Chemical
- ▶ Fuel storage facilities and transfer terminals
- ▶ Power generation
- ▶ Wood processing
- ▶ Other heavy and mid-heavy industries

Main features

- ▶ The use of any additional junction boxes during installation is eliminated by the flexible combination of cable entries (up to 4 cable glands, through-wiring system) at both ends of the luminaire
- ▶ Designed for both indoor and outdoor use
- ▶ Hinged diffuser and gear tray
- ▶ The interior design focuses on ergonomics for installers and service personnel: quick opening, no loose parts that could fall out when opened, precisely fitted components
- ▶ 4 versions: general lighting, self-contained emergency lighting, and Central Battery System emergency lighting (including a special version for EATON central battery with addressable function)
- ▶ 2 lengths: 1276 mm / 670 mm
- ▶ 3 types of diffuser: transparent / frosted / opal
- ▶ 3 power of LED modules (luminous efficiency of the luminaire up to 142 lm/W)

Two sizes

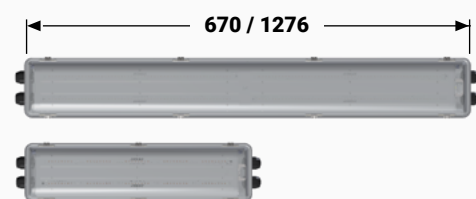



Integrated isolator switch – safety and simplified maintenance

PrimeLine luminaires in explosion-proof design can optionally be equipped with an integrated isolator switch that automatically disconnects the power supply when the diffuser is opened. This feature significantly improves operational safety and simplifies both maintenance and testing procedures, especially in demanding industrial environments.

Key benefits of the integrated isolator switch:

- ▶ **Increased user safety** – automatic power disconnection when opening the enclosure eliminates the risk of electric shock
- ▶ **Protection of internal components** – prevents damage to electronics or batteries by ensuring no voltage is present in the enclosure during maintenance
- ▶ **Facilitates functional testing** – allows safe and independent access to the enclosure without shutting down the entire circuit, saving time during diagnostics
- ▶ **Compliance with ATEX and IECEx requirements** – certified for use in explosive atmospheres, ensuring maximum operational safety
- ▶ **High mechanical durability** of the switch (up to 300,000 operations) – guarantees long-term reliability throughout the enclosure's lifecycle
- ▶ **Wide operating temperature range** – the switch can operate in temperatures from -40°C to +100°C, making it suitable for extreme industrial conditions

*The isolating switch is not available with emergency luminaires equipped with a backup battery.

Up to 4 cable glands + through-wiring

The PrimeLine luminaire features a versatile through-wiring system. It supports the installation of up to **four M20 or M25 plastic or metal cable glands** and allows flexible positioning of the power terminals, enabling connection of up to **four cables (1 incoming, 3 outgoing)**. This setup allows for easy interconnection of multiple luminaires into larger systems, while significantly reducing the need for costly Ex-rated junction boxes (the luminaire itself functions as a junction box), as well as minimizing the use of cables and cable trays.

Available cable glands configurations:

- ▶ 1 gland
- ▶ 2 glands – on one side / on both sides
- ▶ 3 glands – two on one side, one on the other
- ▶ 4 glands – two on each side



▶ Reduced use of power cables ▶ The luminaire functions as an Ex-rated junction box ▶ Flexible configuration of cable glands and terminals



▶ Higher installation costs ▶ Increased use of Ex-rated junction boxes ▶ Increased use of installation materials





Centrally controlled emergency lighting system

PrimeLine emergency luminaires are equipped with an integrated EATON monitoring module, allowing for direct integration with modern central power supply and monitoring systems. This enables each luminaire to be individually monitored and controlled from a central unit, without the need for additional devices. PrimeLine luminaires are fully compatible with EATON central battery systems, making them easy to integrate into advanced emergency lighting monitoring and management systems.

This setup provides numerous operational benefits:

- ▶ **Automatic execution of function and duration tests** with centralized logging of operating status and functional errors
- ▶ **Significant cost savings**, as manual testing is no longer required
- ▶ **High level of safety** through continuous monitoring of luminaire
- ▶ **Simplified installation** – power supply and data transmission use a single line
- ▶ **Shared mains and emergency power connection**, with no need for a separate data line
- ▶ **Up to 20 luminaires** can be connected to a single circuit
- ▶ **Individual switching** of each emergency luminaire within the circuit
- ▶ Fully **compatible with EATON** central battery systems



Real battery charging at -20°C (verified by an accredited testing body)

The PrimeLine Luminaire has undergone a comprehensive test program verified by an independent testing body. The results confirm its ability to reliably charge the battery at ambient temperatures down to -20°C.

This capability is ensured not only during normal operation - when the internal heat slightly rises the temperature inside the luminaire and improves charging conditions - but, crucially, also when the luminaire is switched off and the internal temperature truly reaches -20°C. The distinguishes PrimeLine from many emergency luminaires for which operation at sub-zero temperatures does not necessarily imply reliable battery charging under the same conditions.

This advanced capability offers a range of key benefits:

- ▶ Many emergency luminaires are rated for sub-zero operation but still require battery charging at -20°C, as confirmed by independent testing.
- ▶ Reliable battery charging even when the luminaire is switched off - charging performance is maintained when the luminaire is not operating and the internal temperature of the luminaire reaches the actual -20°C, not only during operation, when internal heat may improve thermal conditions.
- ▶ **No need for additional heating** elements or enclosures, eliminating typical workarounds required to maintain charging conditions in cold environments and reducing installation complexity and costs.
- ▶ Reliability also confirmed at high operating temperatures by certification, ensuring stable performance across critical thermal conditions.
- ▶ Suitable for outdoor installations exposed to harsh weather conditions, loading docks, unheated warehouses, cold storage facilities, and industrial freezers, including real internal luminaire temperatures down to -20°C.





Durable and sealed to the core – built for extreme conditions

The PrimeLine luminaire is engineered for use in harsh and hazardous environments, offering reliable performance in areas exposed to dust, moisture, chemicals, or outdoor conditions. Its rugged construction and high ingress protection rating make it ideal for demanding industrial applications. The materials and sealing system ensure long-term resistance to external factors and mechanical stress.

Key features and benefits:

- ▶ **IP67 protection** – tested for resistance to dust ingress and powerful water jets, including temporary immersion
- ▶ **GRP housing** – glass-fibre reinforced polyester body for high mechanical and chemical resistance
- ▶ **Reinforced polycarbonate diffuser** – impact-resistant and UV-stabilized for outdoor durability
- ▶ **Poured silicone gasket** – long-lasting tightness, resistant to aging and temperature extremes
- ▶ **Stainless steel locking clips** – secure and uniform closure ensuring consistent pressure on the seal
- ▶ **Resistant to UV, dust, chemicals, and weather conditions** – ideal for both indoor and outdoor use
- ▶ **Suitable for Ex zones** – perfect for oil & gas, chemical plants, refineries, and other hazardous areas

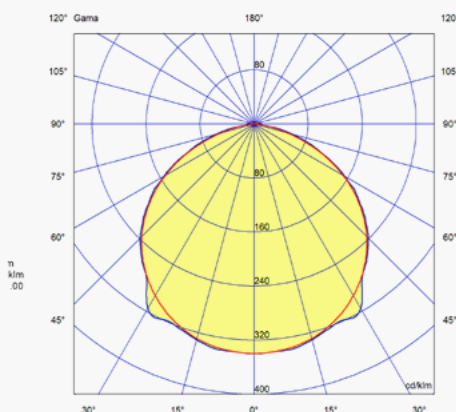
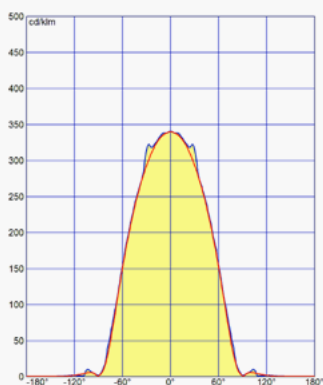
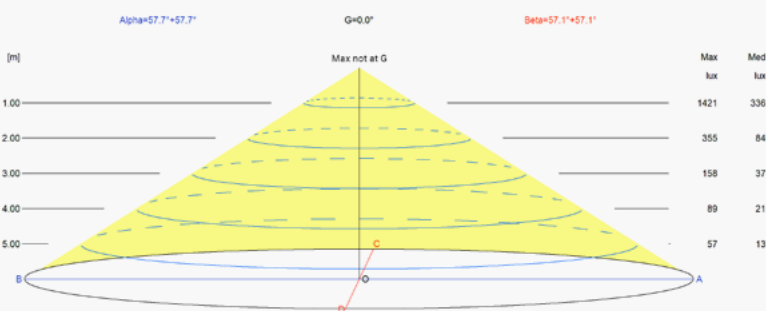

Photometric performance of the PrimeLine luminaire

The PrimeLine series combines robust, explosion-proof construction with high-performance photometric properties, ensuring reliable illumination in demanding industrial environments. Thanks to its wide and uniform light distribution, the luminaire delivers excellent visibility and safety in areas where consistent lighting is essential.

Key features of PrimeLine's photometric performance include:

- ▶ **Wide beam angle** (~115°) enabling effective illumination of large work areas
- ▶ **Uniform light distribution** for visual comfort and reduced glare
- ▶ **High luminous efficacy** with concentrated output in the central axis
- ▶ **Symmetrical intensity** curves in C0–C180 and C90–C270 planes
- ▶ **Up to 5 m mounting height** with clear lux level gradients
- ▶ **Ideal for** use in industrial areas where explosive atmospheres are present

General lighting fixture

Length: 670 mm | **Zones:** 1, 2 and 21, 22 | **Luminous flux:** up to 4185 lm

MARKING	PrimeLine 60-1 *****	PrimeLine 60-2 *****	PrimeLine 60-3 *****
Ex marking	standard: Ex II 2G Ex eb mb IIC T4 Gb Ex II 2D Ex tb IIIC T70°C Db versions with isolation switch: Ex II 2G Ex db eb mb IIC T4 Gb Ex II 2D Ex tb IIIC T70°C Db		
IECEx marking	standard: Ex eb mb IIC T4 Gb Ex tb IIIC T70°C Db versions with isolation switch: Ex eb mb db IIC T4 Gb Ex tb IIIC T70°C Db		
LIGHTING DATA	PrimeLine 60-1 *****	PrimeLine 60-2 *****	PrimeLine 60-3 *****
Lighting source type	2 x LED module 10 W	2 x LED module 12 W	2 x LED module 14 W
Efficiency of the complete luminaire [lm/W] [clear diffuser 4000K]	126 / 134	128 / 136	129 / 137
Colour temperature [K]	standard: 4000K option: 4500K / 5700K / 6500K		
CRI	standard: >80 option: >70 / 90		
Rated luminous flux [lm] for different type of diffuser:	Colour temperature: 4000K		
▶ Transparent	2946	3613	4185
▶ Frosted	2776	3405	3944
▶ Opal	2375	2913	3374
ELECTRICAL DATA	PrimeLine 60-1 *****	PrimeLine 60-2 *****	PrimeLine 60-3 *****
Protection class	I		
Rated power [W]	23,4	28	32,4
Power factor	0,98	0,99	0,99
Rated voltage [V]	AC 110-240, 50Hz DC 125-240, 0Hz or AC 220-240, 50Hz DC 220-240, 0Hz	AC 110-240, 50Hz DC 125-240, 0Hz or AC 220-240, 50Hz DC 220-240, 0Hz	AC 110-240, 50Hz DC 125-240, 0Hz or AC 220-240, 50Hz DC 220-240, 0Hz
Rated current [A]	0,1	0,12	0,14
Cable terminals	min 1,5 mm ² ; max 4 mm ²		
MECHANICAL DATA	PrimeLine 60-1 *****	PrimeLine 60-2 *****	PrimeLine 60-3 *****
Degree of protection	IP66/67		
Impact resistance	7J for the body and 4J for the diffuser		
Body	Glass-fibre reinforced polyester (GRP)		
Diffuser	Polycarbonate in three versions: transparent, opal and frosted		
Gasket	Silicon foam		
Ambient temperature for different type of diffuser:			
▶ Transparent	-40°C ≤ Ta ≤ +50°C (+55°C - option)	-40°C ≤ Ta ≤ +50°C (+55°C - option)	-40°C ≤ Ta ≤ +50°C
▶ Frosted	-40°C ≤ Ta ≤ +50°C (+55°C - option)	-40°C ≤ Ta ≤ +50°C (+55°C - option)	-40°C ≤ Ta ≤ +50°C
▶ Opal	-40°C ≤ Ta ≤ +45°C	-40°C ≤ Ta ≤ +45°C	-40°C ≤ Ta ≤ +45°C

REMARKS: **1)** power tolerance ±10%. **2)** luminous flux tolerance ±10%. **3)** color temperature tolerance ±10%, 4500K, 5700K and 6500K as an option. **4)** Ta=+55°C only operate at a voltage 220-240V. **5)** LED lifetime: 100,000 h (L70B50). **6)** Weight: 9.0 kg. **7)** Warranty: up to 5 years. **8)** Surge protection: 2 kV.

General lighting fixture

Length: 1276 mm | **Zones:** 1, 2 and 21, 22 | **Luminous flux:** up to 8305 lm

MARKING	PrimeLine 12-1 *****	PrimeLine 12-2 *****	PrimeLine 12-3 *****
Ex marking	standard: Ex II 2G Ex eb mb IIC T4 Gb Ex II 2D Ex tb IIIC T70°C Db versions with isolation switch: Ex II 2G Ex db eb mb IIC T4 Gb Ex II 2D Ex tb IIIC T70°C Db		
IECEx marking	standard: Ex eb mb IIC T4 Gb Ex tb IIIC T70°C Db versions with isolation switch: Ex eb mb db IIC T4 Gb Ex tb IIIC T70°C Db		
LIGHTING DATA	PrimeLine 12-1 *****	PrimeLine 12-2 *****	PrimeLine 12-3 *****
Lighting source type	4x LED module 10 W	4x LED module 12 W	4x LED module 14 W
Efficiency of the complete luminaire [lm/W] [clear diffuser 4000K]	135 / 143	135 / 143	134 / 142
Colour temperature [K]	standard: 4000K option: 4500K / 5700K / 6500K		
CRI	standard: >80 option: >70 / 90		
Rated luminous flux [lm] for different type of diffuser:	Colour temperature: 4000K		
▶ Transparent	5979	7293	8305
▶ Frosted	5635	6873	7827
▶ Opal	4820	5880	6696
ELECTRICAL DATA	PrimeLine 12-1 *****	PrimeLine 12-2 *****	PrimeLine 12-3 *****
Protection class	I		
Rated power [W]	43	52,5	62
Power factor	0,95	0,97	0,97
Rated voltage [V]	AC 110-240, 50Hz DC 125-240, 0Hz or AC 220-240, 50Hz DC 220-240, 0Hz	AC 110-240, 50Hz DC 125-240, 0Hz or AC 220-240, 50Hz DC 220-240, 0Hz	AC 110-240, 50Hz DC 125-240, 0Hz or AC 220-240, 50Hz DC 220-240, 0Hz
Rated current [A]	0,2	0,24	0,28
Cable terminals	min 1,5 mm ² ; max 4 mm ²		
MECHANICAL DATA	PrimeLine 12-1 *****	PrimeLine 12-2 *****	PrimeLine 12-3 *****
Degree of protection	IP66/67		
Impact resistance	7J for the body and 4J for the diffuser		
Body	Glass-fibre reinforced polyester (GRP)		
Diffuser	Polycarbonate in three versions: transparent, opal and frosted		
Gasket	Silicon foam		
Ambient temperature for different type of diffuser:			
▶ Transparent	-40°C ≤ Ta ≤ +50°C (+55°C - option)	-40°C ≤ Ta ≤ +50°C (+55°C - option)	-40°C ≤ Ta ≤ +50°C
▶ Frosted	-40°C ≤ Ta ≤ +50°C (+55°C - option)	-40°C ≤ Ta ≤ +50°C (+55°C - option)	-40°C ≤ Ta ≤ +50°C
▶ Opal	-40°C ≤ Ta ≤ +45°C	-40°C ≤ Ta ≤ +45°C	-40°C ≤ Ta ≤ +45°C

REMARKS: **1)** power tolerance ±10%. **2)** luminous flux tolerance ±10%. **3)** color temperature tolerance ±10%, 4500K, 5700K and 6500K as an option. **4)** Ta=+55°C only operate at a voltage 220-240V **5)** LED lifetime: 100,000 h (L70B50). **6)** Weight: 9.0 kg. **7)** Warranty: up to 5 years. **8)** Surge protection: 2 kV.

Emergency Light Fitting [central battery]

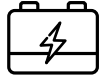

Length: 670 mm | **Zones:** 1, 2 and 21, 22 | **Luminous flux:** up to 4185 lm

MARKING	PrimeLine 60-1 ****X/Y	PrimeLine 60-2 ****X/Y	PrimeLine 60-3 ****X/Y
Ex marking	standard: Ex II 2G Ex eb mb IIC T4 Gb Ex II 2D Ex tb IIIC T70°C Db versions with isolation switch: Ex II 2G Ex db eb mb IIC T4 Gb Ex II 2D Ex tb IIIC T70°C Db		
IECEx marking	standard: Ex eb mb IIC T4 Gb Ex tb IIIC T70°C Db versions with isolation switch: Ex eb mb db IIC T4 Gb Ex tb IIIC T70°C Db		
LIGHTING DATA	PrimeLine 60-1 ****X/Y	PrimeLine 60-2 ****X/Y	PrimeLine 60-3 ****X/Y
Lighting source type	2x LED module 10 W	2x LED module 12 W	2x LED module 14 W
Efficiency of the complete luminaire [lm/W] [clear diffuser 4000K]	115 / 122	122 / 129	125 / 132
Colour temperature [K]	standard: 4000K option: 4500K / 5700K / 6500K		
CRI	standard: >80 option: >70 / 90		
Rated luminous flux [lm] for different type of diffuser:	Colour temperature: 4000K		
▶ Transparent	2946	3613	4185
▶ Frosted	2776	3405	3944
▶ Opal	2375	2913	3374
ELECTRICAL DATA	PrimeLine 60-1 ****X/Y	PrimeLine 60-2 ****X/Y	PrimeLine 60-3 ****X/Y
Protection class	I		
Rated power [W]	24,6	29,4	33,5
Power factor	0,98	0,99	0,99
Rated voltage [V]	AC 220-240, 50Hz DC 220-240, 0Hz	AC 220-240, 50Hz DC 220-240, 0Hz	AC 220-240, 50Hz DC 220-240, 0Hz
Rated current [A]	0,11	0,13	0,15
Cable terminals	min 1,5 mm ² ; max 4 mm ²		
MECHANICAL DATA	PrimeLine 60-1 ****X/Y	PrimeLine 60-2 ****X/Y	PrimeLine 60-3 ****X/Y
Degree of protection	IP66/67		
Impact resistance	7J for the body and 4J for the diffuser		
Body	Glass-fibre reinforced polyester (GRP)		
Diffuser	Polycarbonate in three versions: transparent, opal and frosted		
Gasket	Silicon foam		
Ambient temperature for different type of diffuser:			
▶ Transparent	-30°C ≤ Ta ≤ +50°C	-30°C ≤ Ta ≤ +50°C	-30°C ≤ Ta ≤ +50°C
▶ Frosted	-30°C ≤ Ta ≤ +50°C	-30°C ≤ Ta ≤ +50°C	-30°C ≤ Ta ≤ +50°C
▶ Opal	-30°C ≤ Ta ≤ +45°C	-30°C ≤ Ta ≤ +45°C	-30°C ≤ Ta ≤ +45°C

REMARKS: **1)** power tolerance ±10%. **2)** luminous flux tolerance ±10%. **3)** color temperature tolerance ±10%, 4500K, 5700K and 6500K as an option. **4)** LED lifetime: 100,000 h (L70B50). **5)** Weight: 5.5 kg. **6)** Warranty: up to 5 years. **7)** Surge protection: 2 kV.

Centrally controlled emergency lighting system

PrimeLine emergency luminaires with a CBX-M1/CBY-M1 module are fully compatible with EATON central battery systems. They enable monitoring of lighting systems with individual control of each unit. The control input (L/N) allows parallel switching of mains and emergency lighting,

either locally or remotely (via the STAR command). The system automatically monitors up to 20 luminaires per circuit, significantly reducing inspection time.

Emergency Light Fitting [central battery]

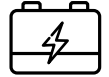

Length: 1276 mm | **Zones:** 1, 2 and 21, 22 | **Luminous flux:** up to 8305 lm

MARKING	PrimeLine 12-1 ****X/Y	PrimeLine 12-2 ****X/Y	PrimeLine 12-3 ****X/Y
Ex marking	standard: Ex II 2G Ex eb mb IIC T4 Gb Ex II 2D Ex tb IIIC T70°C Db versions with isolation switch: Ex II 2G Ex db eb mb IIC T4 Gb Ex II 2D Ex tb IIIC T70°C Db		
IECEx marking	standard: Ex eb mb IIC T4 Gb Ex tb IIIC T70°C Db versions with isolation switch: Ex eb mb db IIC T4 Gb Ex tb IIIC T70°C Db		
LIGHTING DATA	PrimeLine 12-1 ****X/Y	PrimeLine 12-2 ****X/Y	PrimeLine 12-3 ****X/Y
Lighting source type	4x LED module 10 W	4x LED module 12 W	4x LED module 14 W
Efficiency of the complete luminaire [lm/W] [clear diffuser 4000K]	131 / 139	131 / 139	131 / 139
Colour temperature [K]	standard: 4000K option: 4500K, 5700K / 6500K		
CRI	standard: >80 option: >70 / 90		
Rated luminous flux [lm] for different type of diffuser:	Colour temperature: 4000K		
▶ Transparent	5979	7293	8305
▶ Frosted	5635	6873	7827
▶ Opal	4820	5880	6696
ELECTRICAL DATA	PrimeLine 12-1 ****X/Y	PrimeLine 12-2 ****X/Y	PrimeLine 12-3 ****X/Y
Protection class	I		
Rated power [W]	44,2	54	63,5
Power factor	0,95	0,97	0,97
Rated voltage [V]	AC 220-240, 50Hz DC 220-240, 0Hz	AC 220-240, 50Hz DC 220-240, 0Hz	AC 220-240, 50Hz DC 220-240, 0Hz
Rated current [A]	0,2	0,25	0,3
Cable terminals	min 1,5 mm ² ; max 4 mm ²		
MECHANICAL DATA	PrimeLine 12-1 ****X/Y	PrimeLine 12-2 ****X/Y	PrimeLine 12-3 ****X/Y
Degree of protection	IP66/67		
Impact resistance	7J for the body and 4J for the diffuser		
Body	Glass-fibre reinforced polyester (GRP)		
Diffuser	Polycarbonate in three versions: transparent, opal and frosted		
Gasket	Silicon foam		
Ambient temperature for different type of diffuser:			
▶ Transparent	-30°C ≤ Ta ≤ +50°C	-30°C ≤ Ta ≤ +50°C	-30°C ≤ Ta ≤ +50°C
▶ Frosted	-30°C ≤ Ta ≤ +50°C	-30°C ≤ Ta ≤ +50°C	-30°C ≤ Ta ≤ +50°C
▶ Opal	-30°C ≤ Ta ≤ +45°C	-30°C ≤ Ta ≤ +45°C	-30°C ≤ Ta ≤ +45°C

REMARKS: **1)** power tolerance ±10%. **2)** luminous flux tolerance ±10%. **3)** color temperature tolerance ±10%, 4500K, 5700K and 6500K as an option. **4)** LED lifetime: 100,000 h (L70B50). **5)** Weight: 9.0 kg. **6)** Warranty: up to 5 years. **7)** Surge protection: 2 kV.

Centrally controlled emergency lighting system

PrimeLine emergency luminaires with a CBX-M1/CBY-M1 module are fully compatible with EATON central battery systems. They enable monitoring of lighting systems with individual control of each unit. The control input (L/N) allows parallel switching of mains and emergency lighting,

either locally or remotely (via the STAR command). The system automatically monitors up to 20 luminaires per circuit, significantly reducing inspection time.

Emergency Light Fitting [battery backup]

1-3h

Length: 670 mm | Zones: 1, 2 and 21, 22 | Luminous flux: up to 3520 lm

MARKING	PrimeLine 60-1 *****1	PrimeLine 60-2 *****1	PrimeLine 60-2 *****3
Ex marking	Ex II 2G Ex eb mb IIC T4 Gb Ex II 2D Ex tb IIIC T70°C Db	Ex II 2G Ex eb mb IIC T4 Gb Ex II 2D Ex tb IIIC T70°C Db	Ex II 2G Ex eb mb IIC T4 Gb Ex II 2D Ex tb IIIC T70°C Db
IECEX marking	Ex eb mb IIC T4 Gb Ex tb IIIC T70°C Db	Ex eb mb IIC T4 Gb Ex tb IIIC T70°C Db	Ex eb mb IIC T4 Gb Ex tb IIIC T70°C Db
LIGHTING DATA	PrimeLine 60-1 *****1	PrimeLine 60-2 *****1	PrimeLine 60-2 *****3
Emergency mode duration	1h at $-20 \leq T_a \leq 0^\circ\text{C}$ 1,5h at $0 \leq T_a \leq +40^\circ\text{C}$	1,5h	3h
Lighting source type	2x LED module 10 W	2x LED module 12 W	2x LED module 12 W
Luminous flux in emergency mode [lm]	840-1050 640-800 (-20 up to $+40^\circ\text{C}$)	440-550 280-350 (-20 up to $+40$)	360-450
Colour temperature [K]	standard: 4000K option: 4500K / 5700K / 6500K		
CRI	standard: >80 option: >70 / 90		
Efficiency of the complete luminaire [lm/W] [clear diffuser 4000K]	107 / 114	113 / 120	113 / 120
Rated luminous flux [lm] for different type of diffuser:	Colour temperature: 4000K		
▶ Transparent	2930	3520	3520
▶ Frosted	2761	3317	3317
▶ Opal	2362	2838	2838
ELECTRICAL DATA	PrimeLine 60-1 *****1	PrimeLine 60-2 *****1	PrimeLine 60-2 *****3
Protection class	I		
Rated power [W]	27,2	31,6	31,6
Power factor	0,91	0,93	0,93
Rated voltage [V]	AC 220-240, 50Hz	AC 220-240, 50Hz	AC 220-240, 50Hz
Rated current [A]	0,13	0,15	0,15
Cable terminals	min 1,5 mm ² ; max 4 mm ²		
MECHANICAL DATA	PrimeLine 60-1 *****1	PrimeLine 60-2 *****1	PrimeLine 60-2 *****3
Degree of protection	IP66/67		
Impact resistance	7J for the body and 4J for the diffuser		
Body	Glass-fibre reinforced polyester (GRP)		
Diffuser	Polycarbonate in three versions: transparent, opal and frosted		
Gasket	Silicon foam		
Ambient temperature for different type of diffuser:			
▶ Transparent	$0^\circ\text{C} \leq T_a \leq +45^\circ\text{C}$	$0^\circ\text{C} \leq T_a \leq +45^\circ\text{C}$	$0^\circ\text{C} \leq T_a \leq +45^\circ\text{C}$
▶ Frosted	$0^\circ\text{C} \leq T_a \leq +45^\circ\text{C}$	$0^\circ\text{C} \leq T_a \leq +45^\circ\text{C}$	$0^\circ\text{C} \leq T_a \leq +45^\circ\text{C}$
▶ Opal	$0^\circ\text{C} \leq T_a \leq +40^\circ\text{C}$	$0^\circ\text{C} \leq T_a \leq +40^\circ\text{C}$	$0^\circ\text{C} \leq T_a \leq +40^\circ\text{C}$
▶ Option for all above types	$-20 \leq T_a \leq +40^\circ\text{C}$	$-20 \leq T_a \leq +40^\circ\text{C}$	

REMARKS: **1)** power tolerance $\pm 10\%$. **2)** luminous flux tolerance $\pm 10\%$. **3)** Color temperature tolerance $\pm 10\%$, 4500K, 5700K and 6500K as an option. **4)** The lighting fixture version designed to operate at $T_a = -20^\circ\text{C}$ is available only with a 4000 mAh battery pack and without through-wiring; any of the available diffuser types may be used. **5)** Emergency versions for $T_a = -20^\circ\text{C}$ and PrimeLine 60-*****1/3 versions are available only without through-wiring. **6)** The operating time of the 60-1*****1 fixture in emergency mode is 1 h at $-20 \leq T_a \leq 0^\circ\text{C}$ and 1.5 h at $0 \leq T_a \leq +40^\circ\text{C}$. **7)** LED lifetime: 100,000 h (L70B50). **8)** Weight: 9.0 kg. **9)** Warranty: up to 5 years. **10)** Surge protection: 2 kV. **11)** The short emergency luminaire version (models designated 60-1*****1/3) is not available with through-wiring. **12)** The operating time of the 60-1*****1 fixture in emergency mode is 1 h at $-20 \leq T_a \leq 0^\circ\text{C}$ and 1.5 h at $0 \leq T_a \leq +40^\circ\text{C}$.

Emergency luminaire with backup battery for sub-zero temperatures

PrimeLine is one of the first emergency luminaires in the world that, in its battery-powered version, can operate reliably in ambient temperatures as low as -20°C . Thanks to this innovation, PrimeLine significant-

ly expands the scope of where emergency lighting can be safely and effectively used, setting a new standard for performance in demanding environments.



Emergency Light Fitting [battery backup]

1-3h

Length: 1276 mm | **Zones:** 1, 2 and 21, 22 | **Luminous flux:** up to 8349 lm

Ex marking	Ex II 2G Ex eb mb IIC T4 Gb Ex II 2D Ex tb IIIC T70°C Db		
IECEX marking	Ex eb mb IIC T4 Gb Ex tb IIIC T70°C Db		
LIGHTING DATA	PrimeLine 12-2 *****1	PrimeLine 12-3 *****1	PrimeLine 12-2 *****3
Emergency mode duration	1,5h	1,5h	3h
Lighting source type	4x LED module 12 W	4x LED module 14 W	4x LED module 12 W
Luminous flux in emergency mode [lm]	360-450 240-300 (-20 up to +40)	480-600 400-500 (-20 up to +40)	360-450
Colour temperature [K]	standard: 4000K option: 4500K / 5700K / 6500K		
CRI	standard: >80 option: >70 / 90		
Efficiency of the complete luminaire [lm/W] [clear diffuser 4000K]	126 / 133	128 / 136	126 / 133
Rated luminous flux [lm] for different type of diffuser:	Colour temperature: 4000K		
▶ Transparent	7259	8349	7259
▶ Frosted	6852	7868	6852
▶ Opal	5891	6731	5891
ELECTRICAL DATA	PrimeLine 12-2 *****1	PrimeLine 12-3 *****1	PrimeLine 12-2 *****3
Protection class	I		
Rated power [W]	56,5	64,7	56,5
Power factor	0,97	0,98	0,97
Rated voltage [V]	AC 220-240, 50Hz	AC 220-240, 50Hz	AC 220-240, 50Hz
Rated current [A]	0,25	0,29	0,25
Cable terminals			
MECHANICAL DATA	PrimeLine 12-2 *****1	PrimeLine 12-3 *****1	PrimeLine 12-2 *****3
Degree of protection	IP66/67		
Body	Glass-fibre reinforced polyester (GRP)		
Diffuser	Polycarbonate in three versions: transparent, opal and frosted		
Gasket	Silicon foam		
Ambient temperature for different type of diffuser:			
▶ Transparent	0°C ≤ Ta ≤ +45°C	0°C ≤ Ta ≤ +45°C	0°C ≤ Ta ≤ +45°C
▶ Frosted	0°C ≤ Ta ≤ +45°C	0°C ≤ Ta ≤ +45°C	0°C ≤ Ta ≤ +45°C
▶ Opal	0°C ≤ Ta ≤ +40°C	0°C ≤ Ta ≤ +40°C	0°C ≤ Ta ≤ +40°C
▶ Option for all above types	-20 ≤ Ta ≤ + 40°C	-20 ≤ Ta ≤ + 40°C	---

REMARKS: **1)** power tolerance ±10%. **2)** luminous flux tolerance ±10%. **3)** color temperature tolerance ±10%, 4500K, 5700K and 6500K as an option. **4)** LED lifetime: 100,000 h (L70B50). **5)** Weight: 9.0 kg. **6)** Warranty: up to 5 years. **7)** Surge protection: 2 kV.

Emergency luminaire with backup battery for sub-zero temperatures

PrimeLine is one of the first emergency luminaires in the world that, in its battery-powered version, can operate reliably in ambient temperatures as low as -20°C. Thanks to this innovation, PrimeLine significantly expands the scope

of where emergency lighting can be safely and effectively used, setting a new standard for performance in demanding environments.

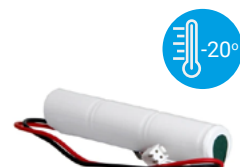

Dimensions and mounting elements

Dimensions depend on mounting type	H	B1
Eyelet hanger R20	136,0	---
Pole mount bracket R50	156,2	---
Ceiling bracket D18	119,0	157
Ceiling bracket D40	143,7	200
Ceiling bracket C	153,4	---
Wall bracket K45	184,7	---

Fixture type	L	L1	B
PrimeLine 60-*****	670	400	173
PrimeLine 12-*****	1276	800	173

Ceiling bracket D18 (code M1)

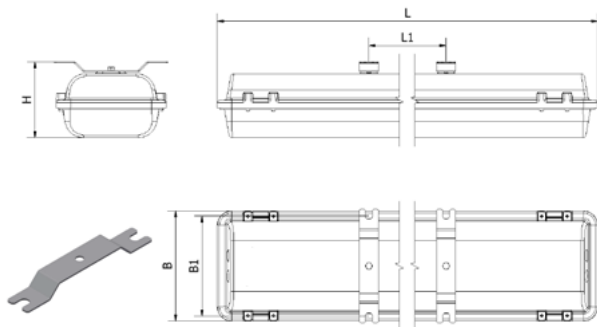

Ceiling bracket D40 (code M2)

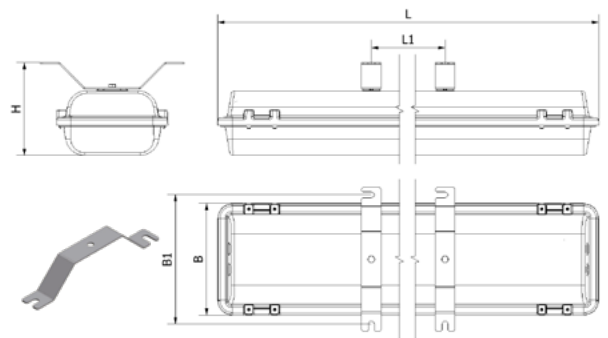

Ceiling bracket C (code M4)

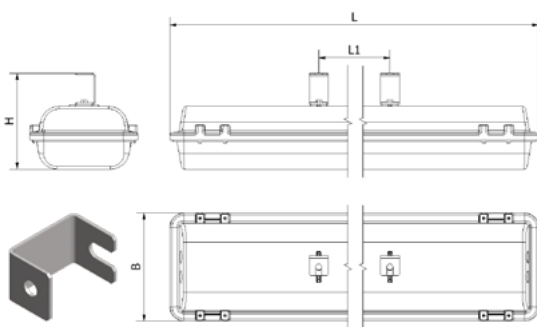

Wall bracket K45 (code M3)

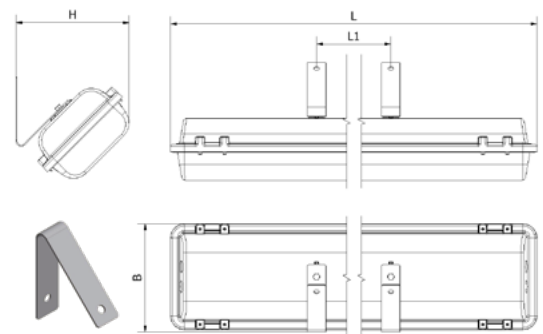

Eyelet hanger R20 (code M5)

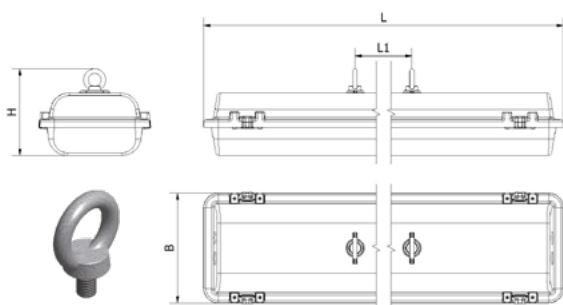

Pole mount bracket R50 (code M6)

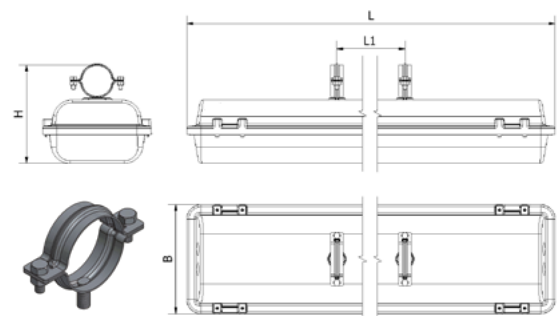

Configuration chart

	Length of luminaire	LED module power	Wiring	Cable glands arrangement	Cable glands size	Luminaire function	Isolating switch	Diffuser type	Temperature version
PrimeLine	AA	B	X	Y	Z	C	R	K	
	60	1	3	1	0	S	O	T	LT
	12	2	5	2	5	1	R	M	HT
		3	7	3		3		O	
				4		B			
				5		X			
						Y			

Length of luminaire

60	670 mm
12	1276 mm

LED module power

1	2 x LED modules for fixture 670 / 4 x LED modules for fixture 1276, power of a single LED module is ~ 10 W each LED module ^[1]
2	2 x LED modules for fixture 670 / 4 x LED modules for fixture 1276, power of a single LED module is ~ 12 W each LED module
3	2 x LED modules for fixture 670 / 4 x LED modules for fixture 1276, power of a single LED module is ~ 14 W each LED module ^[2]

Wiring

3	3-pole terminal (x2 in case of through wiring)
5	5-pole terminal (x2 in case of through wiring)
7	3-pole terminal (x2 in case of through wiring)

Cable glands arrangement

1	one cable gland
2	one cable gland on each side of the fixture
3	two cable glands on one side and one on the other side of the fixture
4	two cable glands on each side of the fixture
5	two cable glands on one side of the fixture

Cable glands size

0	M20
5	M25

Luminaire function

S	baseline version of the fixture
1	emergency version of the fixture with 1.5 h Ni-Cd maintenance battery ^[3]
3	emergency version of the fixture with 3 h Ni-Cd maintenance battery
B	emergency luminaire for operation with central battery system without monitoring
X	emergency luminaire for operation with central battery with monitoring - EATON V-CG-S addressable module
Y	emergency luminaire for operation with central battery with monitoring - EATON V-CG-SE addressable module

Isolation switch

O	without isolation switch
R	with isolation switch ^[4]

Diffuser type

T	transparent diffuser
M	frosted diffuser
O	opal diffuser

Temperature version

LT	special low-temperature version - option available for emergency luminaires with backup battery (luminaire function: 1 and 3)
HT	special high-temperature version - option available for standard luminaires and emergency luminaires for central battery systems without monitoring (Luminaire function: B and S)

Adnotation:

- [1] unavailable version 12-1 *****1/3 (with 1.5 h and 3 h Ni-Cd maintenance battery)
- [2] unavailable version 60-3 *****1/3 (with 1.5 h and 3 h Ni-Cd maintenance battery)
- [3] unavailable version 60-1 *****3 (with 3 h Ni-Cd maintenance battery)
- [4] isolation switch is not available with version *- *****1/3 (with 1.5 h and 3 h Ni-Cd maintenance battery)