

HARDO.



USE AND MAINTENANCE INSTRUCTION OF
LIGHTING FIXTURE

OptiLine **_*****CBX/CBY SERIES



Instruction no: K-26190-PW-0007
Release date: 07.11.2024
Issue no: 1.3

HARDO Czapski i Wspólnicy Sp. j.
ul. Spacerowa 5
32-083 Balice

Table of contents

1. GENERAL INFORMATION	3
1.1 Producer.....	3
1.3 Compliance with standards and regulations	3
2. DEVICE DESCRIPTION	3
2.1 Possible configuration.....	4
2.2 Ex marking.....	5
3. SAFETY	6
3.1 General precautions.....	6
3.2 Application	7
3.3 Other conditions for safe use.....	7
4. TRANSPORT AND STORAGE.....	7
5. INSTALLATION	7
5.1 Before installation	7
5.2 Installation.....	8
5.3 Electrical connection	10
5.3.1 General requirements.....	10
5.3.2 Execution of luminaire electrical connections.....	10
6. WORK IN EMERGENCY MODE	11
7. CLEANING	11
8. MAINTENANCE	11
8.1 Visual and close inspections.....	12
8.2 Detailed inspections	12
8.3 Additional requirements.....	12
9. REPAIRS	12
10. DISPOSAL.....	13
11. WARRANTY CONDITIONS	13
12. TECHNICAL DATA	13
12.1 Electrical and environmental parameters	13
12.2 Photometric data.....	13
12.3 Dimensions.....	14

1. GENERAL INFORMATION

1.1 Producer

HARDO CZAPSKI I WSPÓLNICY SP. J.
Ul. Spacerowa 5
32-83 Balice, Polska

1.2 Information on this manual



WARNING: BEFORE USING THE DEVICE, READ THESE INSTRUCTIONS.

This manual describes the rules for safe and correct handling of devices. The safety recommendations contained in the manual, accident prevention measures as well as general safety measures must be followed. The instructions should be accessible to operating and maintenance personnel and kept throughout the useful life of the product.

1.3 Compliance with standards and regulations

OptiLine series lighting fixtures have been designed and manufactured in accordance with the requirements of:

- a) Directive on the harmonization of the laws of the Member States relating to equipment and protective systems intended for use in potentially explosive atmospheres **ATEX 2014/34/EU**.
- b) Directive on electrical equipment designed for use within certain voltage limits **LVD 2014/35/EU**
- c) Directive on the harmonisation of the laws of the Member States relating to electromagnetic compatibility **EMC 2014/30/EU**.

A detailed summary of standards is included in the EU declaration of conformity.

2. DEVICE DESCRIPTION

OptiLine luminaires are luminaires equipped with high-efficiency LED light sources. Depending on the version, they can be used as basic and/or emergency lighting. The product meets the essential safety requirements contained in the ATEX Directive for category II devices of categories 3G, 2D and 3D, as well as the requirements of the IECEx system. Detailed guidance on potentially explosive atmospheres is given in this document.

Luminaires are approved for use in both external and internal installations. The external housing of OptiLine luminaires is made of glass fibre reinforced polyester (GRP) bottom body and made of polycarbonate (PC) diffuser which is also the lampshade of the luminaire. The luminaire shade is available in three versions: transparent, opal and frosted. It is possible to use LED drivers with the DALI system in luminaires.

The connection of both these elements is sealed with a gasket made of silicone foam.

External electrical cables have to be introduced into the housing using certified cable glands. Depending on the components used, they have a degree of protection against the ingress of solids and liquids at the level of IP 66/67. The housing of the luminaires is resistant to moisture and UV radiation, which allows it to work in outdoor conditions. The housing materials used provide high resistance to mechanical impact. The luminaire is made as a single-chamber device. The housing is closed/opened by means of stainless steel closing clips that prevent the housing from being opened without a tool. Inside the housing, there is a bottom frame made of powder-coated steel. Depending on the configuration of the luminaire, the lower frame is a place of installation for: LED driver, cable connectors, through wiring, NiCD battery pack, CBX and CBY switching modules. The bottom frame is attached to the GRP bottom body with plastic mounting screws. The HEX5416 1/2/3 LED light modules are mounted to the powder-coated steel top frame. Both frames are connected to each other by means of a set of rivet nuts and bolts.

2.1 Possible configuration

OptiLine luminaires **-*-*-*-*CBX/CBY are available in two lengths. In the basic operation mode, they are powered by 230VAC, 50Hz. In the emergency mode, the luminaires are adapted to work with CEAG central battery systems. Luminaires are equipped with addressable modules CBX or CBY.

These modules enable cooperation and monitoring of luminaires through central battery systems in Cewa-Guard-Technology/Star Technology systems. Determination of individual addresses of individual luminaires is carried out at the production stage. The appropriate indication of the address shall be placed on the information label.

A detailed description of the possible configurations and their coding is in accordance with the diagram shown in Figure 1.

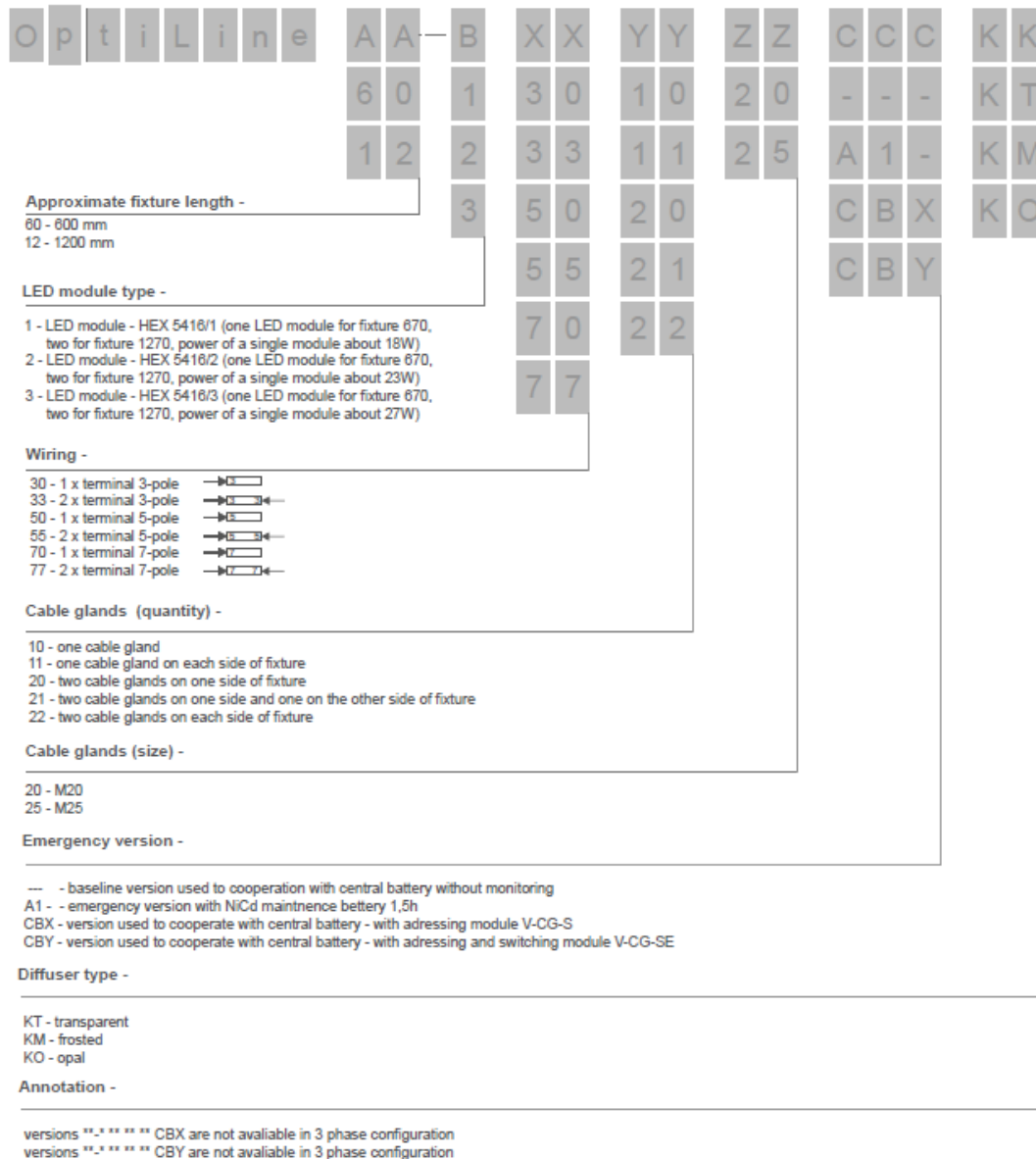

Figure 1. Diagram of all possible configurations of OptiLine luminaires

OptiLine 60-*****--- lighting fixtures are also available in a version with safety signs (pictograms). The use of pictograms requires the installation of diffusing lenses in accordance with the manufacturer's guidelines.

Table 1 shows the basic parameters of the available pictograms.

Pictogram parameters for the OptiLine 60-*****---	
Length [mm]	273
Width [mm]	127
Viewing distance [m]	24
Luminance [cd/m ²]	≥ 300

Table 1. Basic information about available pictograms for the OptiLine 60-*****---

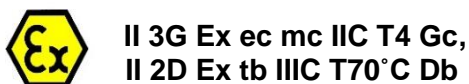

Figure 2. Example of an OptiLine luminaire with a pictogram

The standard set of available pictograms can be found in the catalog card of the OptiLine lighting fixture.

2.2 Ex marking

Depending on the version OptiLine series luminaires are marked with Ex features as follow:



The individual symbols means:

Name	Symbol	Description
Explosion protection marking		Compliant with European Directive 2014/34/EU (ATEX) for installation in hazardous areas.
Device group	II	Device intended for use in explosive atmospheres other than underground mining plants.
Category of devices	3G	The device can be safely operated in explosion hazard Zone 2 of gases, vapours and mists of flammable liquids with air.
	2D	The device can be safely operated in dust explosion Zone 21 or 22.
Type of protection	Ex ec	Protection of equipment with increased safety construction "e".

	Ex mc	Encapsulation protection.
	Ex db	Protection of devices against ignition of dust by means of a "t" housing.
Explosives group	IIC	The device can be used in the presence of explosion hazard of gases, vapours and mists of flammable liquids with air classified as explosion group IIA, IIB or IIC.
	IIIC	The device can be used in the presence of explosion hazard of flammable dust and fibres belonging to the explosion groups IIIA, IIIB and IIIC (all types of dust).
Temperature class	T4	The device is designed for use in hazardous areas of gases with a self-ignition temperature of > 135°C.
Temperature	70°C	The device can be used in the presence of dust whose cloud auto-ignition temperature is higher than 105°C and the smoldering temperature of the layer (5mm) is higher than 145°C.
Explosion protection level	Gc	Equipment intended for installation in gas explosion hazard Zone 2 which provides a 'normal level of safety' and which will not become a source of ignition under normal conditions of use and during expected failure.
	Db	Equipment intended for installation in dust explosion hazards 21, 22 which provides a "high level of safety" and which will not become a source of ignition under normal conditions of use and during expected damage.

3. SAFETY

3.1 General precautions



DANGER: THE EXPLOSION HAZARD CAUSED BY IMPROPER USE AND/OR ALTERATIONS TO THE DEVICE CAN CAUSE SERIOUS OR FATAL INJURIES.



WARNING: FAILURE TO COMPLY WITH THE REQUIREMENTS OF THIS MANUAL MAY VOID THE MANUFACTURER'S WARRANTY.



WARNING: FAILURE TO COMPLY WITH THE INSTALLATION AND USE RULES MAY RESULT IN PERSONAL INJURY OR PROPERTY LOSS. THE MANUFACTURER IS NOT RESPONSIBLE IN SUCH CASES.



WARNING: MAKING ANY MODIFICATIONS TO THE DEVICE IS PROHIBITED.



WARNING: BEFORE PERFORMING ANY ASSEMBLY OPERATIONS, INCLUDING OPENING THE CASE, IT IS IMPERATIVE THAT THE DEVICE BE DISCONNECTED FROM THE POWER SOURCE.

Luminaires must be installed and maintained in accordance with the requirements of this manual and in accordance with EN/IEC 60079-14 (current edition).

The Buyer and/or the End User must be aware of the hazards of the electrical, chemical and physical properties of gas, vapours and dust present in the installation. Proper installation and maintenance in accordance with local and national regulations, product specifications are the responsibility of the Buyer and/or the End User.

It is not allowed to use a partially damaged device.

If damage or malfunction is detected, the device should be taken out of service and handed over for repair to the manufacturer's facility or another entity authorized by the manufacturer.

3.2 Application



WARNING: USE THE DEVICE ONLY FOR ITS INTENDED PURPOSE. INCORRECT USE MAY ADVERSELY AFFECT ITS SAFETY AND FUNCTIONING.



WARNING: THE DEVICE MAY BE USED IN POTENTIALLY EXPLOSIVE ATMOSPHERES ONLY AS DEFINED IN THIS MANUAL AND RESULTING FROM THE EX FEATURE ON THE DATA PLATE.

OptiLine series luminaires are designed for use:

- In accordance with the environmental and technical conditions specified in this manual and on the nameplate.
- In external and/or internal installations;
- In Zone 2 of explosion hazard of gases, vapours and mists of flammable liquids classified as explosion group IIA, IIB or IIC and temperature class T1-T4;
- In Zones 21, 22 explosion hazard of flammable fibres of explosive groups IIIA, IIIB, IIIC, whose assumed flash point is higher than 105°C and the smouldering temperature of the dust layer (5mm) higher than 145°C.

3.3 Other conditions for safe use

- The luminaires are suitable for fixed installations only;
- Operation of the luminaire outside the designated ambient temperature range is unacceptable and will lead to faster wear and/or damage. At the same time, it causes the loss of the manufacturer's warranty. Note: The use of a luminaire outside the designated range of ambient temperatures may result in loss of explosion safety measures, e.g. exceeding the temperature class and explosion;
- Each luminaire has a warning plate: **“DO NOT OPEN WHEN ENERGIZED”**;
- The housing body is made of glass fibre reinforced polyester (GRP), while the diffuser is made of polycarbonate (PC), so they should not be exposed to chemicals that may damage them, in particular: oil, acetone, chlorine, ethyl, ether, solvents;
- The luminaire has a degree of photobiological hazard RG1 – do not stare at the working light source;
- Risk of electric shock, take the required precautions, in particular do not open the live luminaire;
- The luminaire must not be installed on vibrating surfaces.

4. TRANSPORT AND STORAGE

Transport of luminaires should be carried out in original unit packaging. Unit and/or bulk packaging should be protected against precipitation during transport.

Luminaires can only be stored in covered rooms at a temperature of +5°C to +35°C and humidity of less than 75%. The premises should be free of corrosive vapours and gases.

5. INSTALLATION

5.1 Before installation

- Make sure that the packaging has not been damaged during transport;
- Unpack the device;
- Remove any packaging elements that could be dangerous to humans, such as belts, plastic bags, etc.

Make sure that:

- The luminaire is suitable for the hazardous area existing at the installation site;
- The group of apparatus is suitable for gases, vapours and/or dust present at the installation site;
- The temperature class and surface temperature of the device is suitable for gases, vapours and / or dust present at the installation site;
- The luminaire is not damaged.

5.2 Installation

OptiLine luminaires have M8 mounting nuts embedded in the GRP lower body. At the place where the nuts are mounted, the mounting brackets must be fixed with M8/15mm bolts and M8 spring washers. M8 screws should be tightened with a force torque of 5-6 Nm.

Installation of OptiLine luminaires on target mounting surfaces should be carried out in accordance with the approved mounting positions shown in Figure 3.



WARNING: IN ANY CASE, THE MINIMUM DISTANCE OF THE LUMINAIRE FROM THE ILLUMINATED SURFACES SHOULD NOT BE LESS THAN 0,5 m.

Mounting of the brackets to mounting surfaces should be carried out using screws or mounting pins appropriate to the weight of the device.



WARNING: FOLLOW THE GENERAL SAFETY RULES.



WARNING: THE LUMINAIRE MUST NOT BE INSTALLED ON VIBRATING SURFACES.

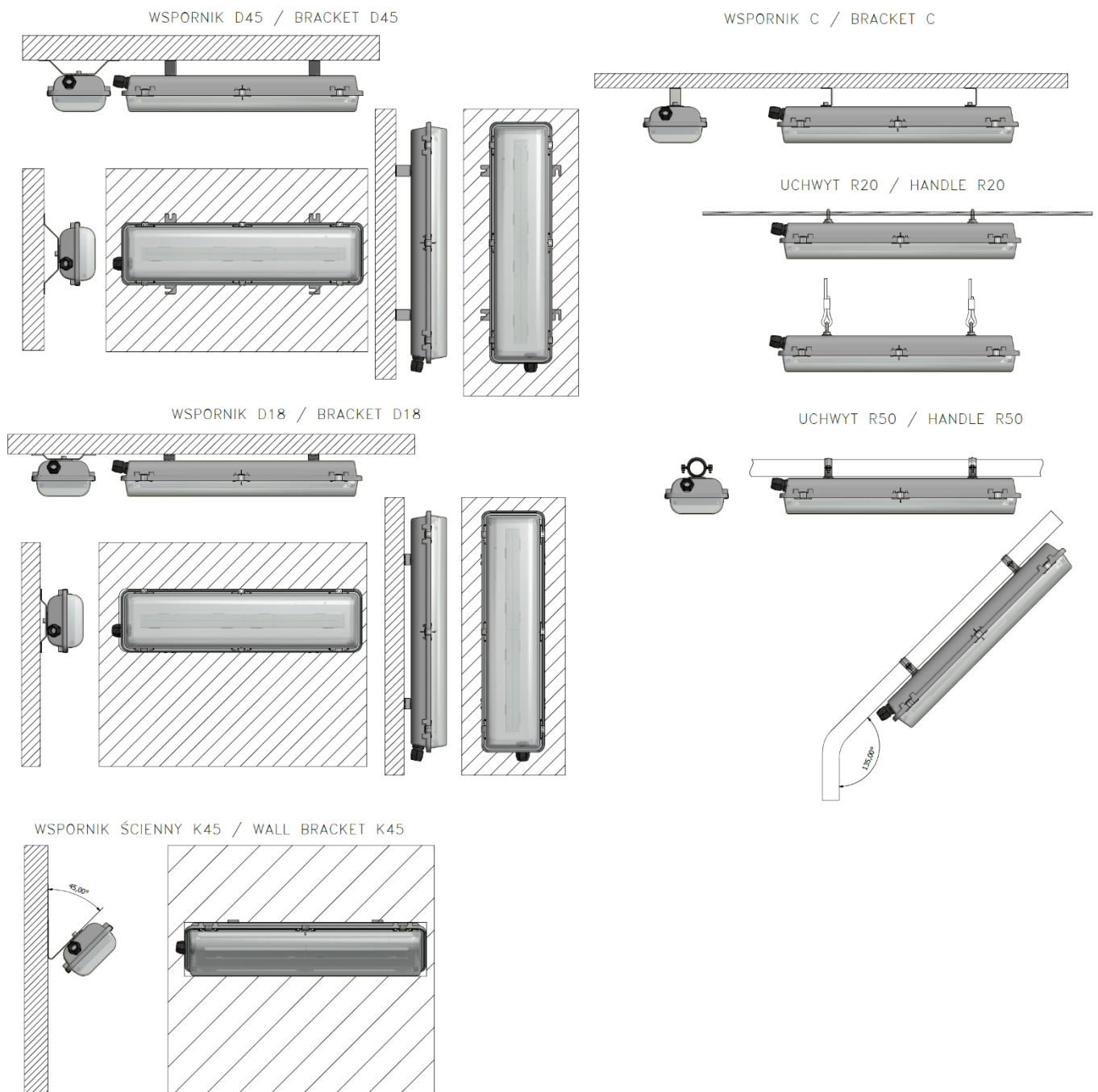

Figure 3. Acceptable mounting position

5.3 Electrical connection

5.3.1 General requirements



WARNING: INSTALLATION AND CONNECTION TO THE ELECTRICAL INSTALLATION SHOULD COMPLY WITH THE REQUIREMENTS OF THE PN-EN/IEC 60079-14 STANDARD.



WARNING: IT IS FORBIDDEN TO MAKE ANY CHANGES TO THE FACTORY CONNECTIONS IN THE LUMINAIRE.

The power cables have to be introduced into the right lighting system by using of certified cable glands. After making the cable connections, you need to clamp the cable gland by tightening the cable gland nut with a wrench. During tightening, protect the cable gland from turning with a second wrench. Clamping the cable gland is designed to protect the power cable against tearing out and against water and dust ingress inside the luminaire.



WARNING: FAILURE TO COMPLY WITH THE ABOVE NOTICE MAY DAMAGE THE SEALS, THEREBY REDUCING THE DEGREE OF PROTECTION AGAINST INGRESS OF DUST AND WATER (IP) AND THUS EXPLOSION SAFETY.

Use power cables with the following parameters:

- Single core cross-section 1.5-4 mm² – for luminaires powered on one side;
- Single core cross-section 2.5-4 mm² – for pass-through or splintered powered luminaires;
- Outer diameter of the cable: 8-17 mm – the value depends on the size and type of cable gland.

The maximum through-currents are:

- $I_{max} = 12$ A for L, N, PE pass-through or splintered connections;
- $I_{max} = 8$ A for L1, L2, L3, N, PE pass-through or splintered connections.



WARNING: THE ABOVE VALUES MUST NOT BE EXCEEDED. AS THIS MAY LEAD TO A DECREASE IN THE SAFETY OF THE LUMINAIRE. THE MANUFACTURER DOES NOT BEAR ANY RESPONSIBILITY IN SUCH CASES.

5.3.2 Execution of luminaire electrical connections

In order to make electrical connections, use a flat tip screwdriver to open the mounting clips and tilt or remove the polycarbonate diffuser. Then, using a screwdriver, unscrew the two non-loose screws located on both shorter sides of the upper frame (reflector), tilt the reflector, cable terminals are mounted below on the lower base.

Remove 8-10 mm of insulation from the wires then connect to the cable terminals in accordance with the markings placed on the cable terminals.

For OptiLine **-*****CBX/CBY possible connection diagrams are available in Figure 3.

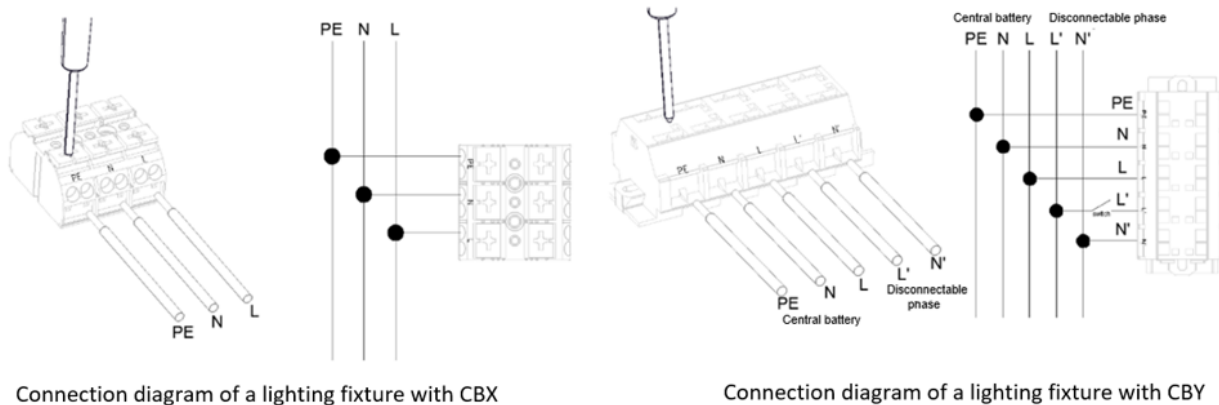

Figure 4. Possible connection diagrams of OptiLine **-*****CBX/CBY

After making connections, the earthing efficiency should be checked in accordance with local regulations and the luminaire should be closed again, i.e.:

- Set the top base (reflector) in the starting position;
- Tighten two non-loose screws with a screwdriver;
- Close the protective diffuser made of polycarbonate with clips.

6. WORK IN EMERGENCY MODE

In the basic operation mode, OptiLine luminaires**-*****CBX, CBY are powered by a central battery system with a mains voltage of 230VAC,50Hz. Loss of mains voltage causes OptiLine**-*****CBX/CBY luminaires to automatically enter emergency mode when powered by backup batteries that are part of the central battery. The supply voltage is then 230VDC, 0Hz. The standard power (luminous flux) of a luminaire supplied from a central battery with DC voltage is 50% of the power (luminous flux) value of the luminaire supplied with mains voltage. In accordance with paragraph 12 of the instructions. Functional and capacity tests (emergency time) are performed from the central battery.

7. CLEANING



WARNING: ELECTROSTATIC HAZARD.

Each luminaire has a warning plate reading: "**WARNING: ELECTROSTATIC HAZARD**". Dust and dust must not accumulate on the housing surfaces. Cleaning should be carried out with a soft cloth with the addition of an antistatic agent or suitable vacuum cleaners appropriate to the prevailing environmental conditions. It is forbidden to use chemicals that may damage the luminaire or impair functional properties.

8. MAINTENANCE



WARNING: SERVICE AND MAINTENANCE WORK SHOULD BE CARRIED OUT IN ACCORDANCE WITH THE DETAILED REQUIREMENTS OF PN-EN/IEC 60079-17:2014-05.



WARNING: INSPECTIONS AND MAINTENANCE CAN ONLY BE CARRIED OUT BY TRAINED AND EXPERIENCED PERSONNEL IN ACCORDANCE WITH THE REQUIREMENTS OF PN-EN/IEC 60079-17:2014-05.

8.1 Visual and close inspections

At least once every 1 months, a visual and close inspection of the lighting fixture should be carried out. During the visual inspection, luminaires do not need to be disconnected from the power source. The scope of the inspection should include in particular:

- Visual verification of the correctness of assembly and possible assembly changes;
- Visual check of operation;
- Visual inspection of the condition of power cables and their markings;
- Visual check of the condition of cable glands;
- Visual check of the condition of the PC diffuser and GRP body and gaskets for damages and possible dirt;
- Visual check of the status and legibility of information labels;
- Cleaning the luminaire housing in accordance with the requirements of paragraph 7.

All irregularities identified shall be remedied. A detailed description and scope of activities is included in the PN-EN/IEC 60079-17:2014-05 standard.

8.2 Detailed inspections

At least once every 12 months, a detailed inspection of lighting fixtures should be carried out. During the detailed inspection, the luminaire must be disconnected from the power source.

The scope of the detailed inspection should include:

- Scope of activities for visual and close inspection;
- Checking the condition of protective coatings of internal elements of the lighting fixture;
- Checking the condition of internal components, e.g.: cable connections, cable connectors, power supply, LED modules, cable glands;
- Verification of the installation site in terms of possible environmental changes, e.g.: type of hazardous area, temperature class, surface temperature, tightness class.

All irregularities identified shall be remedied. A detailed description and scope of activities is included in the PN-EN/IEC 60079-17:2014-05 standard.

8.3 Additional requirements



DANGER: EXPLOSION HAZARD. THE FOLLOWING MEASUREMENTS SHALL BE TAKEN IN THE ABSENCE OF AN EXPLOSIVE ATMOSPHERE

In accordance with the requirements of local regulations, electrical tests related to:

- Measurement of the current consumed by the luminaire;
- Measurement of the condition of the insulation;
- Measurement of the effectiveness of the protective connection

9. REPAIRS



WARNING: THE USE OF A DAMAGED DEVICE IS PROHIBITED AS IT MAY LEAD TO PERSONAL INJURY OR PROPERTY LOSS. THE MANUFACTURER DOES NOT BEAR ANY LIABILITY IN SUCH CASES.



WARNING: ALL REPAIRS, INCLUDING REPLACEMENT OF THE LIGHT SOURCE, CAN ONLY BE CARRIED OUT USING ORIGINAL SPARE PARTS AND ONLY BY THE MANUFACTURER OF THE LUMINAIRE OR AN AUTHORIZED SERVICE.

10. DISPOSAL



A symbol placed on the product or on the packaging indicates that the product should not be considered normal household waste but must be recycled for electrical and electronic equipment.

11. WARRANTY CONDITIONS

To read the warranty conditions, please refer to our General Terms and Conditions available at www.hardo.tech

12. TECHNICAL DATA

12.1 Electrical and environmental parameters

The basic electrical parameters of OptiLine **_*****CBX/CBY series luminaires are presented in Table 2.

Type	Power [^] [W]	Power factor	Rated voltage [V]	Ambient temperature [°C]	Protective class	IP
OptiLine 60-1*****CBX/CBY	21,4	0,89	AC 230, 50Hz DC 230, 0Hz	-30≤T _a ≤+50;	I	66/67
OptiLine 60-2*****CBX/CBY	26,1	0,91				
OptiLine 60-3*****CBX/CBY	30,9	0,93				
OptiLine 12-1*****CBX/CBY	39,5	0,95	AC 230, 50Hz DC 230, 0Hz	-30≤T _a ≤+50;		
OptiLine 12-2*****CBX/CBY	49,5	0,96				
OptiLine 12-3*****CBX/CBY	59,0	0,97				

[^] Power values given for AC power supply, power tolerance +/- 5%.

Table 2. The basic electrical parameters of OptiLine **_*****CBX/CBY

12.2 Photometric data

Photometric data for OptiLine **_*****CBX/CBY- for an ambient temperature of +25 °C, a bar temperature of 4000K and a colour rendering index CRI>80 are shown in Table 3.

Type	Luminous flux with AC voltage [lm] [^]			Luminous flux with DC voltage [lm] [^]			Colour Temperature [K]	CRI
	Transparent	Frosted	Opal	Transparent	Frosted	Opal		
OptiLine 60-1*****CBX/CBY	3485	3324	2931	1650	1560	1400	3000K 4000K 5000K	>70 >80 >90
OptiLine 60-2*****CBX/CBY	4422	4218	3719	2150	2040	1820		
OptiLine 60-3*****CBX/CBY	5182	4943	4358	2650	2540	2200		
OptiLine 12-1*****CBX/CBY	6739	6504	5700	3270	3100	2770		
OptiLine 12-2*****CBX/CBY	8665	8363	7329	4100	3890	3480		
OptiLine 12-3*****CBX/CBY	10342	9981	8747	5150	4950	4350		

[^]Possible ranges of luminous flux depending on the type of shade, colour temperature and CRI (transparent, opal or frosted), tolerance +/- 5%.

Table 3. Basic photometric data of OptiLine **_*****CBX/CBY

12.3 Dimensions

Basic dimensions of OptiLine luminaires are shown in Figure 5 and Table 4.

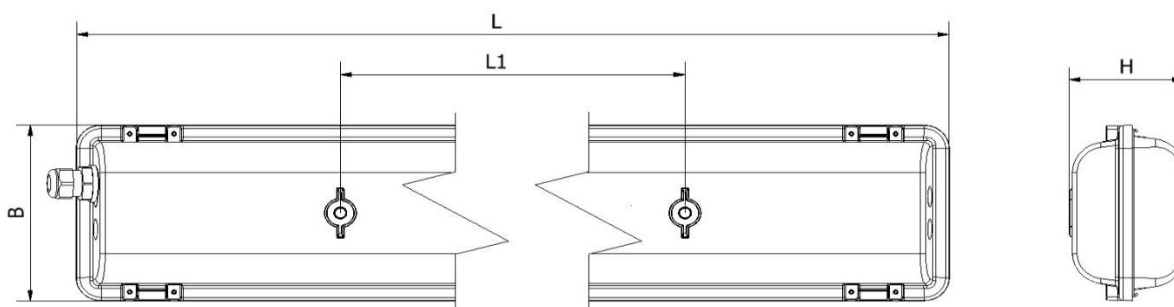

Figure 5. Basic dimensions of OptiLine luminaires

Type	L	L1	B	H
OptiLine 60-*****	670	400	173	107
OptiLine 12-*****	1276	800	173	107

Table 4. Basic dimensions of OptiLine luminaires