

# HARDO.



## USE AND MAINTENANCE INSTRUCTION OF LIGHTING FIXTURE

### PrimeLine \*\*-\*\*\*\*\*S/B SERIES



**Instruction no:** K-27646-PW-0005  
**Release date:** 04.11.2025  
**Issue no:** 1.0

**HARDO Czapski i Wspólnicy Sp. j.**  
Spacerowa 5  
32-083 Balice

## Table of contents

|  |    |
|--|----|
| 1. GENERAL INFORMATION .....                             | 3  |
| 1.1 Manufacturer .....                                   | 3  |
| 1.3 Compliance with standards and regulations .....      | 3  |
| 2. DEVICE DESCRIPTION .....                              | 3  |
| 2.1 Available configurations.....                        | 4  |
| 2.2 Ex marking.....                                      | 5  |
| 3. SAFETY .....  | 6  |
| 3.1 General precautions.....                             | 6  |
| 3.2 Application .....                                    | 6  |
| 3.3 Other conditions for safe use.....                   | 7  |
| 4. TRANSPORT AND STORAGE.....                            | 7  |
| 5. INSTALLATION .....                                    | 7  |
| 5.1 Before installation .....                            | 7  |
| 5.2 Installation.....                                    | 7  |
| 5.3 Electrical connection .....                          | 9  |
| 5.3.1 General requirements.....                          | 9  |
| 5.3.2 Execution of luminaire electrical connections..... | 9  |
| 6. CLEANING .....  | 10 |
| 7. MAINTENANCE .....                                     | 10 |
| 7.1 Visual and close inspections.....                    | 11 |
| 7.2 Detailed inspections .....                           | 11 |
| 7.3 Additional requirements.....                         | 11 |
| 8. REPAIRS.....  | 12 |
| 9. DISPOSAL.....   | 12 |
| 10. WARRANTY CONDITIONS .....                            | 12 |
| 11. TECHNICAL DATA .....                                 | 12 |
| 11.1 Electrical and environmental parameters .....       | 12 |
| 11.2 Photometric data.....                               | 13 |
| 11.3 Dimensions.....                                     | 13 |

## 1. GENERAL INFORMATION

### 1.1 Manufacturer

**HARDO CZAPSKI I WSPÓLNICY SP. J.**  
Ul. Spacerowa 5  
32-083 Balice, Poland

### 1.2 Information on this manual



**NOTE:** BEFORE USING THE DEVICE, READ THESE INSTRUCTIONS.

This manual describes the rules for safe and correct handling of devices. The safety recommendations contained in the manual, accident prevention measures as well as general safety measures must be followed. The instructions should be accessible to operating and maintenance personnel and kept throughout the useful life of the product.

### 1.3 Compliance with standards and regulations

PrimeLine series lighting fixtures have been designed and manufactured in accordance with the requirements of:

- a) Directive on the harmonization of the laws of the Member States relating to equipment and protective systems intended for use in potentially explosive atmospheres **ATEX 2014/34/EU**.
- b) Directive on electrical equipment designed for use within certain voltage limits **LVD 2014/35/EU**.
- c) Directive on the harmonisation of the laws of the Member States relating to electromagnetic compatibility **EMC 2014/30/EU**.

A detailed summary of standards is included in the EU declaration of conformity.

## 2. DEVICE DESCRIPTION

PrimeLine lighting fixtures are equipped with high-efficiency LED light sources. Depending on the version, they can serve as primary and/or emergency lighting. The product meets the essential safety requirements outlined in the ATEX Directive for Group II devices in categories 2G, 3G, 2D, and 3D, as well as the requirements of the IECEx system. Detailed guidelines regarding hazardous areas are provided later in this manual.

The lighting fixtures are approved for use in both indoor and outdoor installations. The external housing of PrimeLine lighting fixtures consists of a lower body made of glass fiber-reinforced polyester (GRP) and a polycarbonate (PC) upper body, which also serves as the fixture's diffuser. The diffuser is available in three versions: transparent, frosted, and opal. The connection between these two components is sealed with a silicone foam gasket.

External electrical cables are introduced into the housing using certified cable glands. Depending on the components used, the fixtures have an ingress protection rating of IP66/67 against solid objects and liquids. The housing is resistant to moisture and UV radiation, making it suitable for outdoor operation. The materials used ensure high resistance to mechanical impact. The fixture is designed as a single-chamber device. The housing is secured with stainless steel locking clips that prevent opening without the use of tools. Inside the housing, there is a lower frame made of powder-coated steel. Depending on the lighting fixture configuration, the lower frame serves as a mounting base for the LED driver, cable connectors, through-wiring, Ni-Cd battery pack, and CBX-M1, CBY-M1 switching modules. The fixtures can be equipped with LED drivers featuring a DALI system. The lower frame is attached to the GRP lower body using plastic mounting screws. The HEX 2356-1/2/3 LED light modules are mounted onto the upper frame, which is made of powder-coated steel. Both frames are connected using a set of rivet nuts and captive screws.

Fixtures in the shorter length version can be equipped with a safety sign (pictogram).

## 2.1 Available configurations

PrimeLine \*\*-\*\*\*\*\* are available in two lengths and can be powered by 110-240VAC, 50Hz, 125-240VDC, 0Hz or 220-240VAC, 50Hz, 220-240VDC, 0Hz.

A detailed description of the possible configurations and their coding is in accordance with the diagram shown in Figure 1. The luminaire can function as basic and emergency lighting without monitoring.

| PrimeLine   | AA | - | B | X | Y | Z | C | R | K |
|---|----|---|---|---|---|---|---|---|---|
|   | 60 |   | 1 | 3 | 1 | 0 | S | O | T |
|   | 12 |   | 2 | 5 | 2 | 5 | B | R | M |
|   |    |   | 3 | 7 | 3 |   | 1 |   | O |
|   |    |   |   |   | 4 |   | 3 |   |   |
|   |    |   |   |   | 5 |   | X |   |   |
|   |    |   |   |   |   |   | Y |   |   |
| <b>Approximate fixture length:</b>  |    |   |   |   |   |   |   |   |   |
| 60 – 670 mm   |    |   |   |   |   |   |   |   |   |
| 12 – 1270 mm  |    |   |   |   |   |   |   |   |   |
| <b>LED module type:</b>   |    |   |   |   |   |   |   |   |   |
| 1 – HEX 2356-* LED module – two LED modules for fixture 670, four for fixture 1270, power of a single LED module is about 10 W <sup>[1]</sup> |    |   |   |   |   |   |   |   |   |
| 2 – HEX 2356-* LED module – two LED modules for fixture 670, four for fixture 1270, power of a single LED module is about 12 W                |    |   |   |   |   |   |   |   |   |
| 3 – HEX 2356-* LED module – two LED modules for fixture 670, four for fixture 1270, power of a single LED module is about 14 W <sup>[2]</sup> |    |   |   |   |   |   |   |   |   |
| <b>Wiring:</b>  |    |   |   |   |   |   |   |   |   |
| 3 – terminal 3-pole   |    |   |   |   |   |   |   |   |   |
| 5 – terminal 5-pole   |    |   |   |   |   |   |   |   |   |
| 7 – terminal 7-pole   |    |   |   |   |   |   |   |   |   |
| <b>Cable glands (quantity):</b>   |    |   |   |   |   |   |   |   |   |
| 1 – one cable gland on one side of the fixture  |    |   |   |   |   |   |   |   |   |
| 2 – one cable gland on each side of the fixture   |    |   |   |   |   |   |   |   |   |
| 3 – two cable glands on one side and one on the other side of the fixture   |    |   |   |   |   |   |   |   |   |
| 4 – two cable glands on each side of the fixture  |    |   |   |   |   |   |   |   |   |
| 5 – two cable glands on one side of the fixture   |    |   |   |   |   |   |   |   |   |
| <b>Cable glands (size):</b>   |    |   |   |   |   |   |   |   |   |
| 0 – M20   |    |   |   |   |   |   |   |   |   |
| 5 – M25   |    |   |   |   |   |   |   |   |   |
| <b>Emergency version:</b>   |    |   |   |   |   |   |   |   |   |
| S – baseline version of the fixture   |    |   |   |   |   |   |   |   |   |
| B – baseline version of the fixture used to cooperation with central battery without monitoring   |    |   |   |   |   |   |   |   |   |
| 1 – emergency version of the fixture with 1,5 h NiCd maintenance battery <sup>[3]</sup>   |    |   |   |   |   |   |   |   |   |
| 3 – emergency version of the fixture with 3 h NiCd maintenance battery  |    |   |   |   |   |   |   |   |   |
| X – version of the fixture used to cooperation with central battery with monitoring - with addressing module V-CG-S                           |    |   |   |   |   |   |   |   |   |
| Y – version of the fixture used to cooperation with central battery with monitoring - with addressing module V-CG-SE                          |    |   |   |   |   |   |   |   |   |
| <b>Isolation switch:</b>  |    |   |   |   |   |   |   |   |   |
| O – without isolation switch  |    |   |   |   |   |   |   |   |   |
| R – with isolation switch <sup>[4]</sup>  |    |   |   |   |   |   |   |   |   |
| <b>Diffuser type:</b>   |    |   |   |   |   |   |   |   |   |
| T – transparent diffuser  |    |   |   |   |   |   |   |   |   |
| M – frosted diffuser  |    |   |   |   |   |   |   |   |   |
| O – opal diffuser   |    |   |   |   |   |   |   |   |   |
| <b>Annotation:</b>  |    |   |   |   |   |   |   |   |   |
| [1] unavailable version 12-1 *****1/3 (with 1,5 h and 3 h NiCd maintenance battery)   |    |   |   |   |   |   |   |   |   |
| [2] unavailable version 60-3 *****1/3 (with 1,5 h and 3 h NiCd maintenance battery)   |    |   |   |   |   |   |   |   |   |
| [3] unavailable version 60-1 *****3 (with 3 h NiCd maintenance battery)   |    |   |   |   |   |   |   |   |   |
| [4] isolation switch is not available with version **-* *****1/3 (with 1,5 h and 3 h NiCd maintenance battery)                                |    |   |   |   |   |   |   |   |   |

\*Available PrimeLine \*\*-\*\*\*\*\*S/B lighting fixture models, along with their parameters, are presented in Chapter 11 of this manual.

Figure 1. Diagram of all possible configurations of PrimeLine luminaires

## 2.2 Ex marking

Depending on the version PrimeLine series luminaires are marked with Ex features as follow:

For gas, vapour and flammable liquid mist explosion hazard zones:



**II 2G Ex eb mb IIC T4 Gb;**

or for versions with isolator switch:



**II 2G Ex db eb mb IIC T4 Gb;**

For flammable dust explosion hazard zones:



**II 2D Ex tb IIIC T70°C Db.**

The meaning of the individual symbols is presented in Table 1.

Table 1. The meaning of the individual symbols

| Name                         | Symbol | Description   |
|------------------------------|--------|---|
| Explosion protection marking |        | Compliant with European Directive 2014/34/EU (ATEX) for installation in hazardous areas.  |
| Device group                 | II     | Device intended for use in explosive atmospheres other than underground mining plants.  |
| Category of devices          | 2G     | The device can be safely operated in explosion hazard Zone 1 or 2 of gases, vapours and mists of flammable liquids with air.  |
|                              | 2D     | The device can be safely operated in dust explosion Zone 21 or 22.  |
| Type of protection           | Ex eb  | Protection of equipment with increased safety construction "e".   |
|                              | Ex mb  | Encapsulation protection.   |
|                              | Ex db  | Protection of equipment by flameproof enclosures "d".   |
|                              | Ex tb  | Protection of devices against ignition of dust by means of a "t" housing.   |
| Explosives group             | IIC    | The device can be used in the presence of explosion hazard of gases, vapours and mists of flammable liquids with air classified as explosion group IIA, IIB or IIC.   |
|                              | IIIC   | The device can be used in the presence of explosion hazard of flammable dust and fibres belonging to the explosion groups IIIA, IIIB and IIIC (all types of dust).  |
| Temperature class            | T4     | The device is designed for use in hazardous areas of gases with a self-ignition temperature of > 135°C.   |
| Temperature                  | 70°C   | The device can be used in the presence of dust whose cloud auto-ignition temperature is higher than 105°C and the smouldering temperature of the layer (5 mm) is higher than 145°C.   |
| Explosion protection level   | Gb     | Equipment intended for installation in gas explosion hazard zones 1, 2 which provides a 'high level of safety' and which will not become a source of ignition under normal conditions of use and during expected damage.    |
|                              | Db     | Equipment intended for installation in dust explosion hazard zones 21, 22 which provides a "high level of safety" and which will not become a source of ignition under normal conditions of use and during expected damage. |

## 3. SAFETY

### 3.1 General precautions



**DANGER:** THE EXPLOSION HAZARD CAUSED BY IMPROPER USE AND/OR ALTERATIONS TO THE DEVICE CAN CAUSE SERIOUS OR FATAL INJURIES.



**WARNING:** FAILURE TO COMPLY WITH THE REQUIREMENTS OF THIS MANUAL MAY VOID THE MANUFACTURER'S WARRANTY.



**WARNING:** FAILURE TO COMPLY WITH THE INSTALLATION AND USE RULES MAY RESULT IN PERSONAL INJURY OR PROPERTY LOSS. THE MANUFACTURER IS NOT RESPONSIBLE IN SUCH CASES.



**WARNING:** MAKING ANY MODIFICATIONS TO THE DEVICE IS PROHIBITED.



**WARNING:** BEFORE PERFORMING ANY ASSEMBLY OPERATIONS, INCLUDING OPENING THE CASE, IT IS IMPERATIVE THAT THE DEVICE BE DISCONNECTED FROM THE POWER SOURCE.

Luminaires must be installed and maintained in accordance with the requirements of this manual and in accordance with EN/IEC 60079-14 (current edition).

The Buyer and/or the End User must be aware of the hazards of the electrical, chemical and physical properties of gas, vapours and dust present in the installation. Proper installation and maintenance in accordance with local and national regulations, product specifications are the responsibility of the Buyer and/or the End User. It is not allowed to use a partially damaged device.

**If damage or malfunction is detected, the device should be taken out of service and handed over for repair to the manufacturer's facility or another entity authorized by the manufacturer.**

### 3.2 Application



**WARNING:** USE THE DEVICE ONLY FOR ITS INTENDED PURPOSE. INCORRECT USE MAY ADVERSELY AFFECT ITS SAFETY AND FUNCTIONING.



**WARNING:** THE DEVICE MAY BE USED IN POTENTIALLY EXPLOSIVE ATMOSPHERES ONLY AS DEFINED IN THIS MANUAL AND RESULTING FROM THE EX FEATURE ON THE DATA PLATE.

PrimeLine series luminaires are designed for use:

- In accordance with the environmental and technical conditions specified in this manual and on the nameplate;
- In external and/or internal installations;
- In Zones 1, 2 of explosion hazard of gases, vapours and mists of flammable liquids classified as explosion group IIA, IIB or IIC and temperature class T1-T4;
- In Zones 21, 22 explosion hazard of flammable fibres of explosive groups IIIA, IIIB, IIIC, whose assumed flash point is higher than 105°C and the smouldering temperature of the dust layer (5 mm) higher than 145°C.

## 3.3 Other conditions for safe use

- The luminaires are suitable for fixed installations only;
- Operation of the luminaire outside the designated ambient temperature range is unacceptable and will lead to faster wear and/or damage. At the same time, it causes the loss of the manufacturer's warranty. Note: The use of a luminaire outside the designated range of ambient temperatures may result in loss of explosion safety measures, e.g. exceeding the temperature class and explosion;
- Each luminaire has a warning plate: “**DO NOT OPEN WHEN ENERGIZED**”;
- The housing body is made of glass fibre reinforced polyester (GRP), while the diffuser is made of polycarbonate (PC), so they should not be exposed to chemicals that may damage them, in particular: oil, acetone, chlorine, ethyl, ether, solvents;
- The luminaire has a degree of photobiological hazard RG1 – do not stare at the working light source;
- Risk of electric shock, take the required precautions, in particular do not open the live luminaire;
- The luminaire must not be installed on vibrating surfaces.
- The equipment shall only be employed with a power supply which has a prospective short circuit current not exceeding 1500A.

## 4. TRANSPORT AND STORAGE

Transport of luminaires should be carried out in original unit packaging. Unit and/or bulk packaging should be protected against precipitation during transport.

Luminaires can only be stored in covered rooms at temperatures from +5°C to +35°C and humidity below 75%. The premises should be free of corrosive vapours and gases.

## 5. INSTALLATION

### 5.1 Before installation

- Make sure that the packaging has not been damaged during transport;
- Unpack the device;
- Remove any packaging elements that could be dangerous to humans, such as belts, plastic bags, etc.

Make sure that:

- The luminaire is suitable for the hazardous area existing at the installation site;
- The group of apparatus is suitable for gases, vapours and/or dust present at the installation site;
- The temperature class and surface temperature of the device is suitable for gases, vapours and/or dust present at the installation site;
- The luminaire is not damaged.

### 5.2 Installation

PrimeLine luminaires have M8 mounting nuts embedded in the GRP lower body. At the place where the nuts are mounted, the mounting brackets must be fixed with M8/15 mm bolts and M8 spring washers. M8 screws should be tightened with a torque of 5-6 Nm. Installation of PrimeLine luminaires on target mounting surfaces should be carried out in accordance with the approved mounting positions shown in Figure 2.



**WARNING:** IN ANY CASE, THE MINIMUM DISTANCE OF THE LUMINAIRE FROM THE ILLUMINATED SURFACES SHOULD NOT BE LESS THAN 0,5 M.

Mounting of the brackets to mounting surfaces should be carried out using screws or mounting pins appropriate to the weight of the device.



**WARNING:** FOLLOW THE GENERAL SAFETY RULES.



**WARNING:** THE LUMINAIRE MUST NOT BE INSTALLED ON VIBRATING SURFACES.

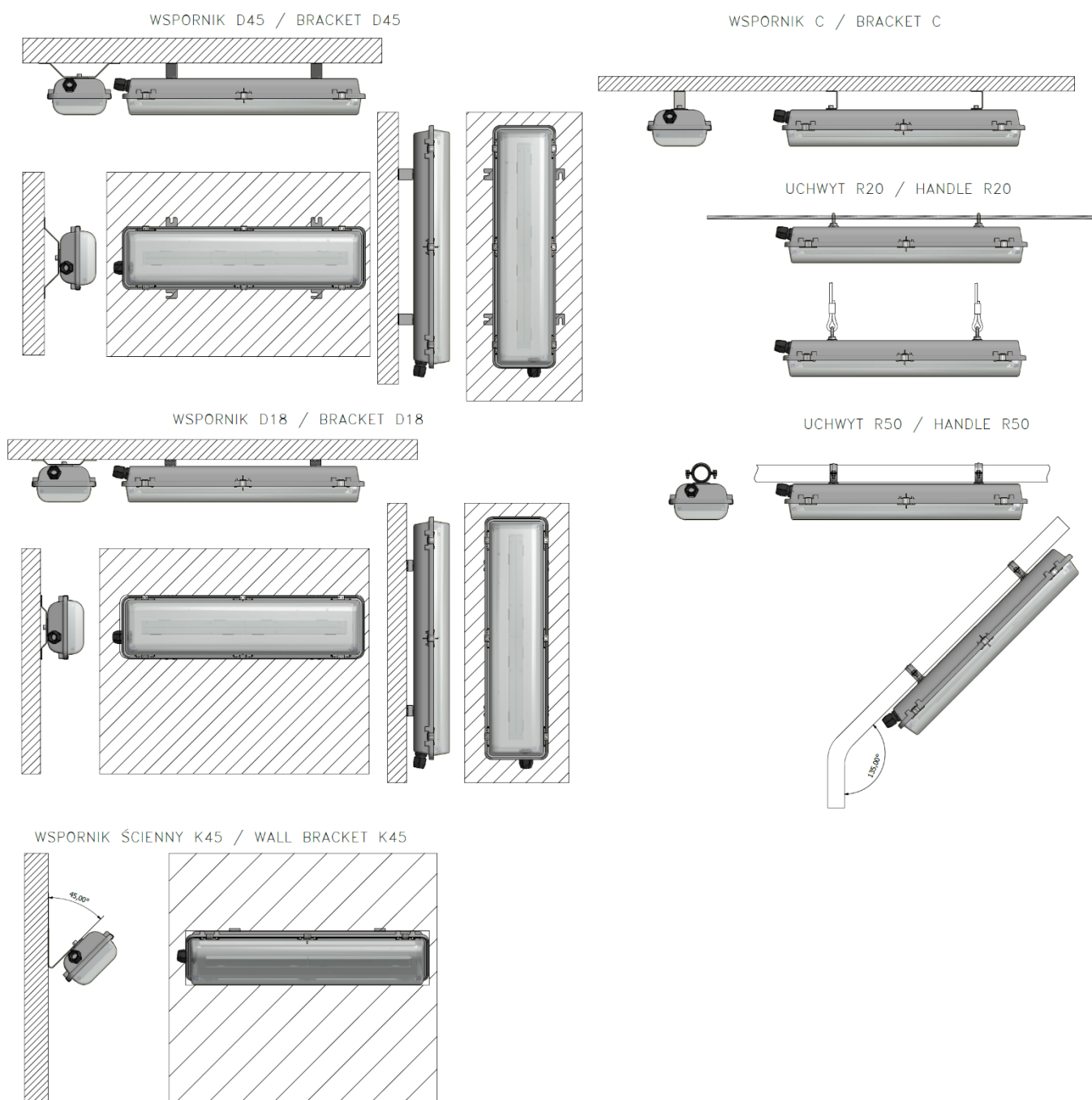

Figure 2. Acceptable mounting position

## 5.3 Electrical connection

### 5.3.1 General requirements



**WARNING:** INSTALLATION AND CONNECTION TO THE ELECTRICAL INSTALLATION SHOULD COMPLY WITH THE REQUIREMENTS OF THE PN-EN/IEC 60079-14 STANDARD.



**WARNING:** IT IS FORBIDDEN TO MAKE ANY CHANGES TO THE FACTORY CONNECTIONS IN THE LUMINAIRE.

The power cables have to be introduced into the right lighting system by using of certified cable glands. After making the cable connections, you need to clamp the cable gland by tightening the cable gland nut with a wrench. During tightening, protect the cable gland from turning with a second wrench. Clamping the cable gland is designed to protect the power cable against tearing out and against water and dust ingress inside the luminaire.



**WARNING:** FAILURE TO COMPLY WITH THE ABOVE NOTICE MAY DAMAGE THE SEALS, THEREBY REDUCING THE DEGREE OF PROTECTION AGAINST INGRESS OF DUST AND WATER (IP) AND THUS EXPLOSION SAFETY.

Use power cables with the following parameters:

- Single core cross-section 1.5-4 mm<sup>2</sup> – for luminaires powered on one side;
- Single core cross-section 2.5-4 mm<sup>2</sup> – for pass-through or crossed powered luminaires;
- Outer diameter of the cable: 8-17 mm – the value depends on the size and type of cable gland.

The maximum through-currents are:

- $I_{\max} = 12$  A for L, N, PE pass-through or crossed connections;
- $I_{\max} = 8$  A for L1, L2, L3, N, PE pass-through or crossed connections.



**WARNING:** THE ABOVE VALUES MUST NOT BE EXCEEDED. AS THIS MAY LEAD TO A DECREASE IN THE SAFETY OF THE LUMINAIRE. THE MANUFACTURER DOES NOT BEAR ANY RESPONSIBILITY IN SUCH CASES.

### 5.3.2 Execution of luminaire electrical connections

In order to make electrical connections, use a flat tip screwdriver to open the mounting clips and tilt or remove the polycarbonate diffuser. Then, using a screwdriver, unscrew the two non-loose screws located on both shorter sides of the upper frame (reflector), tilt the reflector, cable terminals are mounted below on the lower base.

Remove 8-10 mm of insulation from the wires then connect to the cable terminals in accordance with the markings placed on the cable terminals.

For PrimeLine \*\*-\*\*\*\*\* possible connection diagrams are available in Figure 3. For DALI power supply, see markings on enclosure.

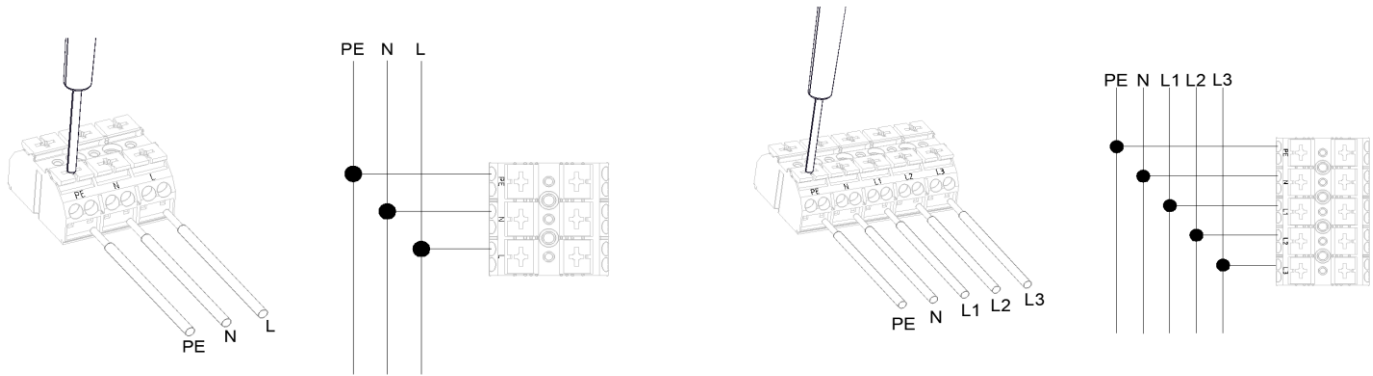

Figure 3. Possible connection diagrams of PrimeLine luminaires \*\*-\*\*\*\*\*

For safety and to eliminate the risk of damaging the lighting fixture components, electrical connections must be made in the order specified by the manufacturer. The power supply must not operate without a load. The sequence of connections is as follows:

- Connect the light source – LED modules;
- Connect the power supply from the central battery (applies to the PrimeLine \*\*-\*\*\*\*\*B fixture);  
Connect the main power supply.

After making connections, the earthing efficiency should be checked in accordance with local regulations and the luminaire should be closed again, i.e.:

- Set the top base (reflector) in the starting position;
- Tighten two non-loose screws with a screwdriver;
- Close the protective diffuser made of polycarbonate with clips.

If it becomes necessary to switch off the lighting fixture, first disconnect the mains power supply and then disconnect it from the central battery (applies to the PrimeLine \*\*-\*\*\*\*\*B fixture).



**WARNING:** THE ORDER OF PERFORMING ACTIVITIES RELATED TO ELECTRICAL CONNECTIONS MUST BE STRICTLY FOLLOWED. FAILURE TO FOLLOW THE SEQUENCE WILL RESULT IN DAMAGE TO THE LIGHTING FIXTURE COMPONENTS.

## 6. CLEANING



**WARNING:** ELECTROSTATIC HAZARD.

Each luminaire has a warning plate reading: "**WARNING: ELECTROSTATIC HAZARD**". Dust must not accumulate on the housing surfaces. Cleaning should be carried out with a soft cloth with the addition of an antistatic agent or suitable vacuum cleaners appropriate to the prevailing environmental conditions. It is forbidden to use chemicals that may damage the luminaire or impair functional properties.

## 7. MAINTENANCE



**WARNING:** SERVICE AND MAINTENANCE WORK SHOULD BE CARRIED OUT IN ACCORDANCE WITH THE DETAILED REQUIREMENTS OF PN-EN/IEC 60079-17:2014-05.



**WARNING:** INSPECTIONS AND MAINTENANCE CAN ONLY BE CARRIED OUT BY TRAINED AND EXPERIENCED PERSONNEL IN ACCORDANCE WITH THE REQUIREMENTS OF PN-EN/IEC 60079-17:2014-05.

## ***7.1 Visual and close inspections***

At least once every 3 months, a visual and close inspection of the lighting fixture should be carried out. During the visual inspection, luminaires do not need to be disconnected from the power source. The scope of the inspection should include in particular:

- Visual verification of the correctness of assembly and possible assembly changes;
- Visual check of operation;
- Visual inspection of the condition of power cables and their markings;
- Visual check of the condition of cable glands;
- Visual check of the condition of the PC diffuser and GRP body and gaskets for damages and possible dirt;
- Visual check of the status and legibility of information labels;
- Cleaning the luminaire housing in accordance with the requirements of paragraph 6.

All irregularities identified shall be remedied. A detailed description and scope of activities is included in the PN-EN/IEC 60079-17:2014-05 standard.

## ***7.2 Detailed inspections***

At least once every 12 months, a detailed inspection of lighting fixtures should be carried out. During the detailed inspection, the luminaire must be disconnected from the power source.

The scope of the detailed inspection should include:

- Scope of activities for visual and close inspection;
- Checking the condition of protective coatings of internal elements of the lighting fixture;
- Checking the condition of internal components, e.g.: cable connections, cable connectors, power supply, LED modules, cable glands;
- Verification of the installation site in terms of possible environmental changes, e.g.: type of hazardous area, temperature class, surface temperature, tightness class.

All irregularities identified shall be remedied. A detailed description and scope of activities is included in the PN-EN/IEC 60079-17:2014-05 standard.

## ***7.3 Additional requirements***



**DANGER:** EXPLOSION HAZARD. THE FOLLOWING MEASUREMENTS SHALL BE TAKEN IN THE ABSENCE OF AN EXPLOSIVE ATMOSPHERE.

In accordance with the requirements of local regulations, electrical tests related to:

- Measurement of the current consumed by the luminaire;
- Measurement of the condition of the insulation;
- Measurement of the effectiveness of the protective connection.

## 8. REPAIRS



**WARNING:** THE USE OF A DAMAGED DEVICE IS PROHIBITED AS IT MAY LEAD TO PERSONAL INJURY OR PROPERTY LOSS. THE MANUFACTURER DOES NOT BEAR ANY LIABILITY IN SUCH CASES.



**WARNING:** ALL REPAIRS, INCLUDING REPLACEMENT OF THE LIGHT SOURCE, CAN ONLY BE CARRIED OUT USING ORIGINAL SPARE PARTS AND ONLY BY THE MANUFACTURER OF THE LUMINAIRE, THE SERVICE AGENT OR A SIMILARLY SKILLED PERSON.



**WARNING:** ALL REPAIRS MAY ONLY BE CARRIED OUT IN NON-EXPLOSIVE ATMOSPHERIC CONDITIONS.

## 9. DISPOSAL



A symbol placed on the product or on the packaging indicates that the product should not be considered normal household waste, but must be recycled for electrical and electronic equipment.

## 10. WARRANTY CONDITIONS

To read the warranty conditions, please refer to our General Terms and Conditions available at [www.hardo.tech](http://www.hardo.tech).

## 11. TECHNICAL DATA

### 11.1 Electrical and environmental parameters

The basic electrical parameters of PrimeLine **\*\*\_\*\*\*\*\*** series luminaires for an ambient temperature of +25°C are presented in Table 2.

Table 2. The basic electrical parameters of PrimeLine **\*\*\_\*\*\*\*\***

| Type   | Power* [W] | Power factor | Rated voltage [V]                          | Ambient temperature [°C]   | Protective class | IP    |
|--|------------|--------------|--|--|------------------|-------|
| PrimeLine 60-1*****S<br>PrimeLine 60-1*****B | 23,4       | 0,98         | AC 110-240, 50Hz<br>DC 125-240, 0Hz<br>or  | - 40≤T <sub>a</sub> ≤+50;<br>- 40≤T <sub>a</sub> ≤+55 - option**<br>- 40≤T <sub>a</sub> ≤+45 – <i>with opal diffuser</i> ; | I                | 66/67 |
| PrimeLine 60-2*****S<br>PrimeLine 60-2*****B | 28,0       | 0,99         |  |  |                  |       |
| PrimeLine 60-3*****S<br>PrimeLine 60-3*****B | 32,4       | 0,99         | AC 220-240, 50Hz<br>DC 220-240, 0Hz        | - 40≤T <sub>a</sub> ≤+50<br>- 40≤T <sub>a</sub> ≤+45 – <i>with opal diffuser</i> ;   |                  |       |
| PrimeLine 12-1*****S<br>PrimeLine 12-1*****B | 43,0       | 0,95         | AC 110-240, 50Hz<br>DC 125-240, 0Hz<br>lor | - 40≤T <sub>a</sub> ≤+50;<br>- 40≤T <sub>a</sub> ≤+55 - option**<br>- 40≤T <sub>a</sub> ≤+45 – <i>with opal diffuser</i> ; |                  |       |
| PrimeLine 12-2*****S<br>PrimeLine 12-2*****B | 52,5       | 0,97         |  |  |                  |       |
| PrimeLine 12-3*****S<br>PrimeLine 12-3*****B | 62,0       | 0,97         | AC 220-240, 50Hz<br>DC 220-240, 0Hz        | - 40≤T <sub>a</sub> ≤+50<br>- 40≤T <sub>a</sub> ≤+45 – <i>with opal diffuser</i> ;   |                  |       |

\* Power values given for AC power supply, power tolerance +/- 10%;

The lighting fixture version designed for operation at a temperature of T = 55°C may only operate at a voltage of 220–240 V, while the remaining versions support the nominal voltage range in accordance with the Rated Voltage column in Table 2. Versions designed for operation at T = 55°C are not available with an opal diffuser.

## 11.2 Photometric data

Photometric data for PrimeLine \*\*-\*\*\*\*\* for an ambient temperature of +25°C, a colour temperature of 4000K and a colour rendering index CRI>80 are shown in Table 3.

Table 3. Basic photometric data of PrimeLine \*\*-\*\*\*\*\*

| Type   | Luminous flux with AC voltage* |         |      | CRI               |
|--|--------------------------------|---------|------|-------------------|
|  | [lm]                           |         |      |                   |
|  | 4000                           |         |      |                   |
| Colour temperature** [K]                     | Transparent                    | Frosted | Opal |                   |
| PrimeLine 60-1*****S<br>PrimeLine 60-1*****B | 2946                           | 2776    | 2375 | >70<br>>80<br>>90 |
| PrimeLine 60-2*****S<br>PrimeLine 60-2*****B | 3613                           | 3405    | 2913 |                   |
| PrimeLine 60-3*****S<br>PrimeLine 60-3*****B | 4185                           | 3944    | 3374 |                   |
| PrimeLine 12-1*****S<br>PrimeLine 12-1*****B | 5979                           | 5635    | 4820 |                   |
| PrimeLine 12-2*****S<br>PrimeLine 12-2*****B | 7293                           | 6873    | 5880 |                   |
| PrimeLine 12-3*****S<br>PrimeLine 12-3*****B | 8305                           | 7827    | 6696 |                   |

\* Possible ranges of luminous flux depending on the type of shade, colour temperature and CRI (transparent, opal or frosted), tolerance +/- 10%;

\*\* Available colour temperatures: 4000K, 4500K, 5700K, 6500K, tolerance +/- 5%;

## 11.3 Dimensions

Basic dimensions of PrimeLine luminaires are shown in Figure 4 and Table 4.

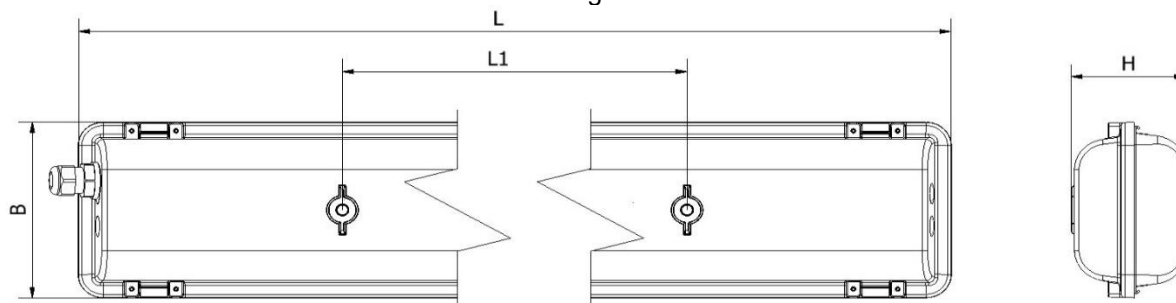

Figure 4. Basic dimensions of PrimeLine luminaires

Table 4. Basic dimensions of PrimeLine luminaires

| Type               | L    | L1  | B   | H   |
|--------------------|------|-----|-----|-----|
| PrimeLine 60-***** | 670  | 400 | 173 | 107 |
| PrimeLine 12-***** | 1276 | 800 | 173 | 107 |